

# SN5451, SN54LS51, SN54S51 SN7451, SN74LS51, SN74S51 AND-OR-INVERT GATES

SDLS113 – DECEMBER 1983 – REVISED MARCH 1988

- Package Options Include Plastic "Small Outline" Packages, Ceramic Chip Carriers and Flat Packages, and Plastic and Ceramic DIPs
- Dependable Texas Instruments Quality and Reliability

## description

The '51 and 'S51 contain two independent 2-wide 2-input AND-OR-INVERT gates. They perform the Boolean function  $Y = \overline{AB + CD}$ .

The 'LS51 contains one 2-wide 3-input and one 2-wide 2-input AND-OR-INVERT gates. They perform the Boolean functions  $1Y = \overline{(1A \cdot 1B \cdot 1C) + (1D \cdot 1E \cdot 1F)}$  and  $2Y = \overline{(2A \cdot 2B) + (2C \cdot 2D)}$ .

The SN5451, SN54LS51, and SN54S51 are characterized for operation over the full military temperature range of  $-55^{\circ}\text{C}$  to  $125^{\circ}\text{C}$ . The SN7451, SN74LS51 and SN74S51 are characterized for operation from  $0^{\circ}\text{C}$  to  $70^{\circ}\text{C}$ .

## logic diagrams

'51, 'S51

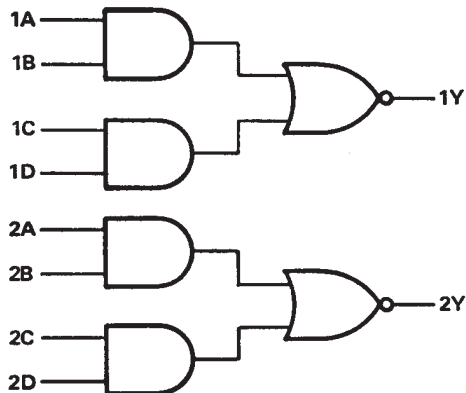

'LS51

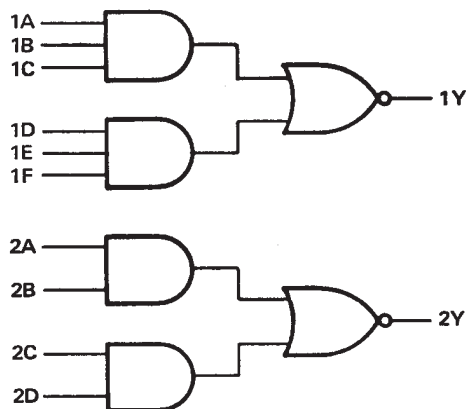

SN5451 . . . J PACKAGE  
SN54S51 . . . J OR W PACKAGE  
SN7451 . . . N PACKAGE  
SN74S51 . . . D OR N PACKAGE

(TOP VIEW)

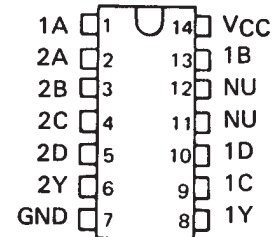

SN5451 . . . W PACKAGE

(TOP VIEW)

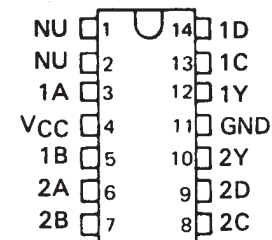

SN54LS51 . . . J OR W PACKAGE  
SN74LS51 . . . D OR N PACKAGE

(TOP VIEW)

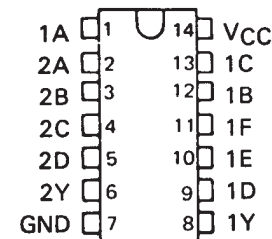

NC - No internal connection

NU - Make no external connection

PRODUCTION DATA information is current as of publication date. Products conform to specifications per the terms of Texas Instruments standard warranty. Production processing does not necessarily include testing of all parameters.

 **TEXAS  
INSTRUMENTS**

POST OFFICE BOX 655303 • DALLAS, TEXAS 75265

Copyright © 1988, Texas Instruments Incorporated

# SN5451, SN54LS51, SN54S51 SN7451, SN74LS51, SN74S51 AND-OR-INVERT GATES

SDLS113 – DECEMBER 1983 – REVISED MARCH 1988

SN54S51 . . . FK PACKAGE  
(TOP VIEW)



SN54LS51 . . . FK PACKAGE  
(TOP VIEW)

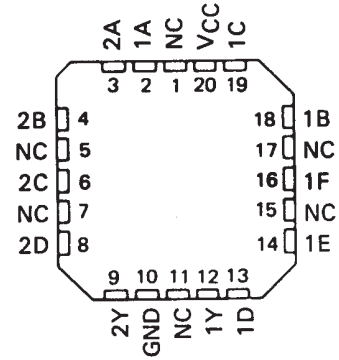

NC - No internal connection  
NU - Make no external connection

## logic symbols†

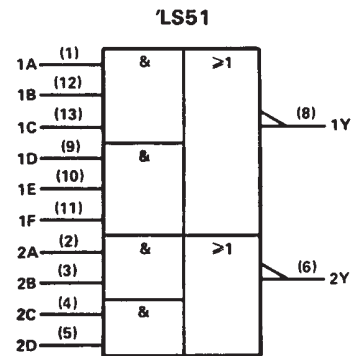

†These symbols are in accordance with ANSI/IEEE Std 91-1984 and IEC Publication 617-12.  
Pin numbers shown are for D, J, N, and W packages.

## schematics

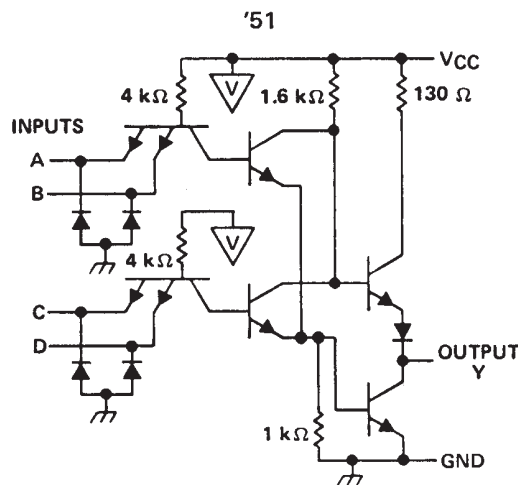



**SN5451, SN54LS51, SN54S51  
SN7451, SN74LS51, SN74S51  
AND-OR-INVERT GATES**

SDLS113 – DECEMBER 1983 – REVISED MARCH 1988

**recommended operating conditions**

	SN5451			SN7451			UNIT
	MIN	NOM	MAX	MIN	NOM	MAX	
V <sub>CC</sub> Supply voltage	4.5	5	5.5	4.75	5	5.25	V
V <sub>IH</sub> High-level input voltage	2			2			V
V <sub>IL</sub> Low-level input voltage			0.8			0.8	V
I <sub>OH</sub> High-level output current			-0.4			-0.4	mA
I <sub>OL</sub> Low-level output current			16			16	mA
T <sub>A</sub> Operating free-air temperature	-55		125	0		70	°C

**electrical characteristics over recommended operating free-air temperature range (unless otherwise noted)**

PARAMETER	TEST CONDITIONS †	SN5451			SN7451			UNIT
		MIN	TYP ‡	MAX	MIN	TYP ‡	MAX	
V <sub>IK</sub>	V <sub>CC</sub> = MIN, I <sub>I</sub> = -12 mA			-1.5			-1.5	V
V <sub>OH</sub>	V <sub>CC</sub> = MIN, V <sub>IL</sub> = 0.8 V, I <sub>OH</sub> = -0.4 mA	2.4	3.4		2.4	3.4		V
V <sub>OL</sub>	V <sub>CC</sub> = MIN, V <sub>IH</sub> = 2 V, I <sub>OL</sub> = 16 mA		0.2	0.4		0.2	0.4	V
I <sub>I</sub>	V <sub>CC</sub> = MAX, V <sub>I</sub> = 5.5 V			1			1	mA
I <sub>IH</sub>	V <sub>CC</sub> = MAX, V <sub>I</sub> = 2.4 V			40			40	µA
I <sub>IL</sub>	V <sub>CC</sub> = MAX, V <sub>I</sub> = 0.4 V			-1.6			-1.6	mA
I <sub>OS</sub> §	V <sub>CC</sub> = MAX	-20		-55	-18		-55	mA
I <sub>CCH</sub>	V <sub>CC</sub> = MAX, V <sub>I</sub> = 0 V		4	8		4	8	mA
I <sub>CCL</sub>	V <sub>CC</sub> = MAX, See Note 2		7.4	14		7.4	14	mA

† For conditions shown as MIN or MAX, use the appropriate value specified under recommended operating conditions.

‡ All typical values are at V<sub>CC</sub> = 5 V, T<sub>A</sub> = 25°C.

§ Not more than one output should be shorted at a time.

NOTE 2: All inputs of one AND gate at 4.5 V, all others at GND.

**switching characteristics, V<sub>CC</sub> = 5 V, T<sub>A</sub> = 25°C (see note 3)**

PARAMETER	FROM (INPUT)	TO (OUTPUT)	TEST CONDITIONS	MIN	TYP	MAX	UNIT
t <sub>PLH</sub>	Any	Y	R <sub>L</sub> = 400 Ω, C <sub>L</sub> = 15 pF		13	22	ns
t <sub>PHL</sub>					8	15	

NOTE 3: Load circuits and voltage waveforms are shown in Section 1.



SN5451, SN54LS51, SN54S51  
 SN7451, SN74LS51, SN74S51  
**AND-OR-INVERT GATES**

SDLS113 – DECEMBER 1983 – REVISED MARCH 1988

recommended operating conditions

	SN54LS51			SN74LS51			UNIT
	MIN	NOM	MAX	MIN	NOM	MAX	
V <sub>CC</sub> Supply voltage	4.5	5	5.5	4.75	5	5.25	V
V <sub>IH</sub> High-level input voltage	2			2			V
V <sub>IL</sub> Low-level input voltage			0.7			0.8	V
I <sub>OH</sub> High-level output current			-0.4			-0.4	mA
I <sub>OL</sub> Low-level output current			4			8	mA
T <sub>A</sub> Operating free-air temperature	-55		125	0		70	°C

electrical characteristics over recommended operating free-air temperature range (unless otherwise noted)

PARAMETER	TEST CONDITIONS †	SN54LS51			SN74LS51			UNIT
		MIN	TYP ‡	MAX	MIN	TYP ‡	MAX	
V <sub>IK</sub>	V <sub>CC</sub> = MIN, I <sub>I</sub> = -18 mA			-1.5			-1.5	V
V <sub>OH</sub>	V <sub>CC</sub> = MIN, V <sub>IL</sub> = MAX, I <sub>OH</sub> = -0.4 mA	2.5	3.4		2.7	3.4		V
V <sub>OL</sub>	V <sub>CC</sub> = MIN, V <sub>IH</sub> = 2 V, I <sub>OL</sub> = 4 mA	0.25	0.4		0.25	0.4		V
	V <sub>CC</sub> = MIN, V <sub>IH</sub> = 2 V, I <sub>OL</sub> = 8 mA				0.35	0.5		
I <sub>I</sub>	V <sub>CC</sub> = MAX, V <sub>I</sub> = 7 V			0.1			0.1	mA
I <sub>IH</sub>	V <sub>CC</sub> = MAX, V <sub>I</sub> = 2.7 V			20			20	μA
I <sub>IL</sub>	V <sub>CC</sub> = MAX, V <sub>I</sub> = 0.4 V			-0.4			-0.4	mA
I <sub>OS</sub> §	V <sub>CC</sub> = MAX	-20		-100	-20		-100	mA
I <sub>CCH</sub>	V <sub>CC</sub> = MAX, V <sub>I</sub> = 0 V		0.8	1.6		0.8	1.6	mA
I <sub>CCL</sub>	V <sub>CC</sub> = MAX, See Note 2		1.4	2.8		1.4	2.8	mA

† For conditions shown as MIN or MAX, use the appropriate value specified under recommended operating conditions.

‡ All typical values are at V<sub>CC</sub> = 5 V, T<sub>A</sub> = 25°C.

§ Not more than one output should be shorted at a time, and the duration of the short-circuit should not exceed one second.

NOTE 2: All inputs of one AND gate at 4.5 V, all others at GND.

switching characteristics, V<sub>CC</sub> = 5 V, T<sub>A</sub> = 25°C (see note 3)

PARAMETER	FROM (INPUT)	TO (OUTPUT)	TEST CONDITIONS	MIN	TYP	MAX	UNIT
t <sub>PLH</sub>	Any	Y	R <sub>L</sub> = 2 kΩ, C <sub>L</sub> = 15 pF		12	20	ns
t <sub>PHL</sub>					12.5	20	

NOTE 3: Load circuits and voltage waveforms are shown in Section 1.



**SN5451, SN54LS51, SN54S51  
SN7451, SN74LS51, SN74S51  
AND-OR-INVERT GATES**

SDLS113 – DECEMBER 1983 – REVISED MARCH 1988

**recommended operating conditions**

	SN54S51			SN74S51			UNIT
	MIN	NOM	MAX	MIN	NOM	MAX	
V <sub>CC</sub> Supply voltage	4.5	5	5.5	4.75	5	5.25	V
V <sub>IH</sub> High-level input voltage	2			2			V
V <sub>IL</sub> Low-level input voltage			0.8			0.8	V
I <sub>OH</sub> High-level output current			-1			-1	mA
I <sub>OL</sub> Low-level output current			20			20	mA
T <sub>A</sub> Operating free-air temperature	-55		125	0		70	°C

**electrical characteristics over recommended operating free-air temperature range (unless otherwise noted)**

PARAMETER	TEST CONDITIONS †	SN54S51			SN74S51			UNIT
		MIN	TYP ‡	MAX	MIN	TYP ‡	MAX	
V <sub>IK</sub>	V <sub>CC</sub> = MIN, I <sub>I</sub> = -18 mA			-1.2			-1.2	V
V <sub>OH</sub>	V <sub>CC</sub> = MIN, V <sub>IL</sub> = 0.8 V, I <sub>OH</sub> = -1 mA	2.5	3.4		2.7	3.4		V
V <sub>OL</sub>	V <sub>CC</sub> = MIN, V <sub>IH</sub> = 2 V, I <sub>OL</sub> = 20 mA			0.5			0.5	V
I <sub>I</sub>	V <sub>CC</sub> = MAX, V <sub>I</sub> = 5.5 V			1			1	mA
I <sub>IH</sub>	V <sub>CC</sub> = MAX, V <sub>I</sub> = 2.7 V			50			50	µA
I <sub>IL</sub>	V <sub>CC</sub> = MAX, V <sub>I</sub> = 0.5 V			-2			-2	mA
I <sub>OS</sub> §	V <sub>CC</sub> = MAX	-40		-100	-40		-100	mA
I <sub>CCH</sub>	V <sub>CC</sub> = MAX, V <sub>I</sub> = 0 V		8.2	17.8		8.2	17.8	mA
I <sub>CCL</sub>	V <sub>CC</sub> = MAX, See Note 2		13.6	22		13.6	22	mA

† For conditions shown as MIN or MAX, use the appropriate value specified under recommended operating conditions.

‡ All typical values are at V<sub>CC</sub> = 5 V, T<sub>A</sub> = 25°C.

§ Not more than one output should be shorted at a time, and the duration of the short-circuit should not exceed one second.

NOTE 2: All inputs of one AND gate at 4.5 V, all others at GND.

**switching characteristics, V<sub>CC</sub> = 5 V, T<sub>A</sub> = 25°C (see note 3)**

PARAMETER	FROM (INPUT)	TO (OUTPUT)	TEST CONDITIONS	MIN	TYP	MAX	UNIT	
t <sub>PLH</sub>	Any	Y	R <sub>L</sub> = 280 Ω, C <sub>L</sub> = 15 pF		3.5	5.5	ns	
t <sub>PHL</sub>					3.5	5.5	ns	
t <sub>PLH</sub>			R <sub>L</sub> = 280 Ω, C <sub>L</sub> = 50 pF			5		ns
t <sub>PHL</sub>						5.5		ns

NOTE 3: Load circuits and voltage waveforms are shown in Section 1.

