

High-Speed CMOS Logic Quad D-Type Flip-Flop with Reset

August 1997 - Revised October 2003

Features

- Common Clock and Asynchronous Reset on Four D-Type Flip-Flops
- Positive Edge Pulse Triggering
- Complementary Outputs
- Buffered Inputs
- Fanout (Over Temperature Range)
 - Standard Outputs 10 LSTTL Loads
 - Bus Driver Outputs 15 LSTTL Loads
- Wide Operating Temperature Range . . . -55°C to 125°C
- Balanced Propagation Delay and Transition Times
- Significant Power Reduction Compared to LSTTL Logic ICs
- HC Types
 - 2V to 6V Operation
 - High Noise Immunity: $N_{IL} = 30\%$, $N_{IH} = 30\%$ of V_{CC} at $V_{CC} = 5V$
- HCT Types
 - 4.5V to 5.5V Operation
 - Direct LSTTL Input Logic Compatibility, $V_{IL} = 0.8V$ (Max), $V_{IH} = 2V$ (Min)
 - CMOS Input Compatibility, $I_I \leq 1\mu A$ at V_{OL} , V_{OH}

advantage of standard CMOS ICs and the ability to drive 10 LSTTL devices.

 Information at the D input is transferred to the Q, \bar{Q} outputs on the positive going edge of the clock pulse. All four Flip-Flops are controlled by a common clock (CP) and a common reset (MR). Resetting is accomplished by a low voltage level independent of the clock. All four Q outputs are reset to a logic 0 and all four \bar{Q} outputs to a logic 1.

Ordering Information

PART NUMBER	TEMP. RANGE (°C)	PACKAGE
CD54HC175F3A	-55 to 125	16 Ld CERDIP
CD54HCT175F3A	-55 to 125	16 Ld CERDIP
CD74HC175E	-55 to 125	16 Ld PDIP
CD74HC175M	-55 to 125	16 Ld SOIC
CD74HC175MT	-55 to 125	16 Ld SOIC
CD74HC175M96	-55 to 125	16 Ld SOIC
CD74HCT175E	-55 to 125	16 Ld PDIP
CD74HCT175M	-55 to 125	16 Ld SOIC
CD74HCT175MT	-55 to 125	16 Ld SOIC
CD74HCT175M96	-55 to 125	16 Ld SOIC

Description

 The 'HC175 and 'HCT175 are high speed Quad D-type Flip-Flops with individual D-inputs and Q, \bar{Q} complementary outputs. The devices are fabricated using silicon gate CMOS technology. They have the low power consumption

NOTE: When ordering, use the entire part number. The suffix 96 denotes tape and reel. The suffix T denotes a small-quantity reel of 250.

Pinout

CD54HC175, CD54HCT175
(CERDIP)
CD74HC175, CD74HCT175
(PDIP, SOIC)
TOP VIEW



Functional Diagram

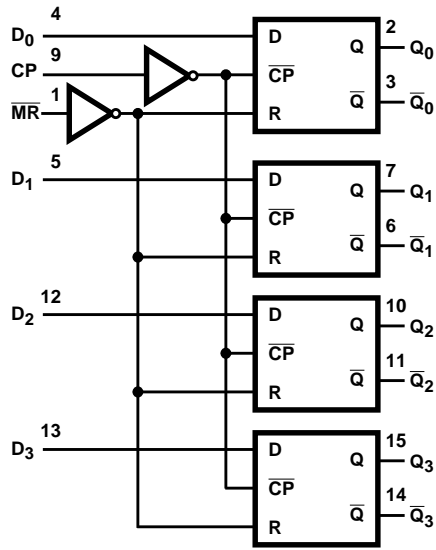

TRUTH TABLE

INPUTS			OUTPUTS	
RESET (MR)	CLOCK CP	DATA D _n	Q _n	\bar{Q}_n
L	X	X	L	H
H	↑	H	H	L
H	↑	L	L	H
H	L	X	Q ₀	\bar{Q}_0

H = High Voltage Level, L = Low Voltage Level, X = Don't Care, ↑ = Transition from Low to High Level, Q₀ = Level Before the Indicated Steady-State Input Conditions Were Established.

Logic Diagram

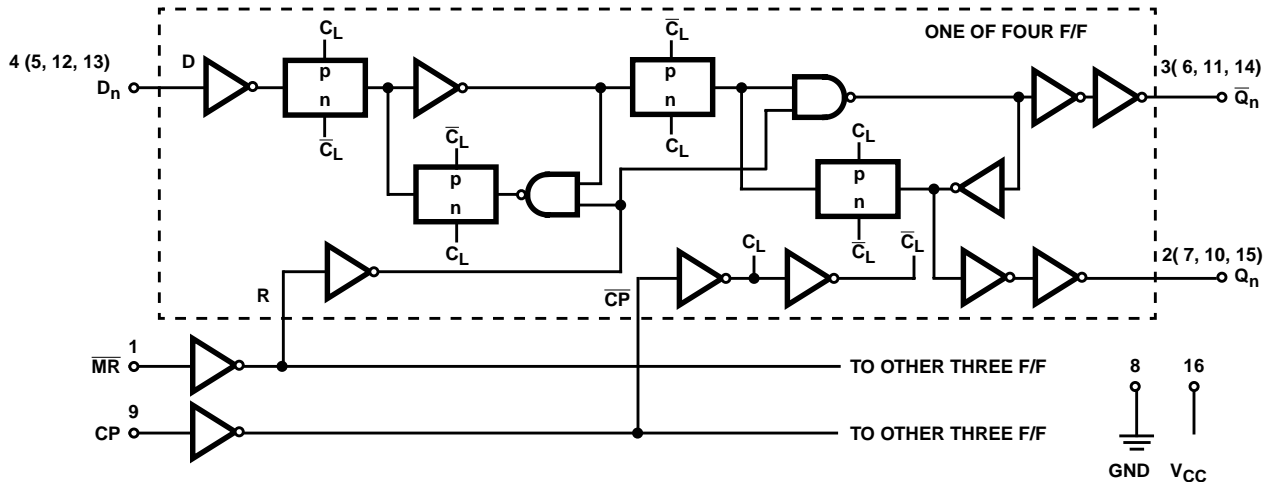

CD54HC175, CD74HC175, CD54HCT175, CD74HCT175

Absolute Maximum Ratings

DC Supply Voltage, V_{CC}	-0.5V to 7V
DC Input Diode Current, I_{IK}	
For $V_I < -0.5V$ or $V_I > V_{CC} + 0.5V$	$\pm 20mA$
DC Output Diode Current, I_{OK}	
For $V_O < -0.5V$ or $V_O > V_{CC} + 0.5V$	$\pm 20mA$
DC Output Source or Sink Current per Output Pin, I_O	
For $V_O > -0.5V$ or $V_O < V_{CC} + 0.5V$	$\pm 25mA$
DC V_{CC} or Ground Current, I_{CC} or I_{GND}	$\pm 50mA$

Thermal Information

Thermal Resistance (Typical, Note 1)	θ_{JA} ($^{\circ}C/W$)
E (PDIP) Package	67
M (SOIC) Package	73
Maximum Junction Temperature	$150^{\circ}C$
Maximum Storage Temperature Range	$-65^{\circ}C$ to $150^{\circ}C$
Maximum Lead Temperature (Soldering 10s)	$300^{\circ}C$ (SOIC - Lead Tips Only)

Operating Conditions

Temperature Range (T_A)	$-55^{\circ}C$ to $125^{\circ}C$
Supply Voltage Range, V_{CC}	
HC Types2V to 6V
HCT Types	4.5V to 5.5V
DC Input or Output Voltage, V_I , V_O	0V to V_{CC}
Input Rise and Fall Time	
2V	1000ns (Max)
4.5V	500ns (Max)
6V	400ns (Max)

CAUTION: Stresses above those listed in "Absolute Maximum Ratings" may cause permanent damage to the device. This is a stress only rating and operation of the device at these or any other conditions above those indicated in the operational sections of this specification is not implied.

NOTE:

- The package thermal impedance is calculated in accordance with JESD 51-7.

DC Electrical Specifications

PARAMETER	SYMBOL	TEST CONDITIONS		V_{CC} (V)	25 $^{\circ}C$			-40 $^{\circ}C$ TO +85 $^{\circ}C$		-55 $^{\circ}C$ TO 125 $^{\circ}C$		UNITS
		V_I (V)	I_O (mA)		MIN	TYP	MAX	MIN	MAX	MIN	MAX	
HC TYPES												
High Level Input Voltage	V_{IH}	-	-	2	1.5	-	-	1.5	-	1.5	-	V
				4.5	3.15	-	-	3.15	-	3.15	-	V
				6	4.2	-	-	4.2	-	4.2	-	V
Low Level Input Voltage	V_{IL}	-	-	2	-	-	0.5	-	0.5	-	0.5	V
				4.5	-	-	1.35	-	1.35	-	1.35	V
				6	-	-	1.8	-	1.8	-	1.8	V
High Level Output Voltage CMOS Loads	V_{OH}	V_{IH} or V_{IL}	-0.02	2	1.9	-	-	1.9	-	1.9	-	V
			-0.02	4.5	4.4	-	-	4.4	-	4.4	-	V
High Level Output Voltage TTL Loads	V_{OH}	V_{IH} or V_{IL}	-0.02	6	5.9	-	-	5.9	-	5.9	-	V
			-4	4.5	3.98	-	-	3.84	-	3.7	-	V
Low Level Output Voltage CMOS Loads	V_{OL}	V_{IH} or V_{IL}	0.02	2	-	-	0.1	-	0.1	-	0.1	V
			0.02	4.5	-	-	0.1	-	0.1	-	0.1	V
Low Level Output Voltage TTL Loads	V_{OL}	V_{IH} or V_{IL}	0.02	6	-	-	0.1	-	0.1	-	0.1	V
			4	4.5	-	-	0.26	-	0.33	-	0.4	V
Input Leakage Current	I_I	V_{CC} or GND	-	6	-	-	± 0.1	-	± 1	-	± 1	μA
Quiescent Device Current	I_{CC}	V_{CC} or GND	0	6	-	-	8	-	80	-	160	μA

CD54HC175, CD74HC175, CD54HCT175, CD74HCT175

DC Electrical Specifications (Continued)

PARAMETER	SYMBOL	TEST CONDITIONS		V _{CC} (V)	25°C			-40°C TO +85°C		-55°C TO 125°C		UNITS
		V _I (V)	I _O (mA)		MIN	TYP	MAX	MIN	MAX	MIN	MAX	
HCT TYPES												
High Level Input Voltage	V _{IH}	-	-	4.5 to 5.5	2	-	-	2	-	2	-	V
Low Level Input Voltage	V _{IL}	-	-	4.5 to 5.5	-	-	0.8	-	0.8	-	0.8	V
High Level Output Voltage CMOS Loads	V _{OH}	V _{IH} or V _{IL}	-0.02	4.5	4.4	-	-	4.4	-	4.4	-	V
High Level Output Voltage TTL Loads			-4	4.5	3.98	-	-	3.84	-	3.7	-	V
Low Level Output Voltage CMOS Loads	V _{OL}	V _{IH} or V _{IL}	0.02	4.5	-	-	0.1	-	0.1	-	0.1	V
Low Level Output Voltage TTL Loads			4	4.5	-	-	0.26	-	0.33	-	0.4	V
Input Leakage Current	I _I	V _{CC} to GND	0	5.5	-	-	±0.1	-	±1	-	±1	μA
Quiescent Device Current	I _{CC}	V _{CC} or GND	0	5.5	-	-	8	-	80	-	160	μA
Additional Quiescent Device Current Per Input Pin: 1 Unit Load	ΔI _{CC} (Note 2)	V _{CC} -2.1	-	4.5 to 5.5	-	100	360	-	450	-	490	μA

NOTES:

2. For dual-supply systems theoretical worst case (V_I = 2.4V, V_{CC} = 5.5V) specification is 1.8mA.

HCT Input Loading Table

INPUT	UNIT LOADS
MR	1
CP	0.60
D	0.15

NOTE: Unit Load is ΔI_{CC} limit specified in DC Electrical Specifications table, e.g. 360μA max at 25°C.

Prerequisite For Switching Specifications

PARAMETER	SYMBOL	TEST CONDITIONS	V _{CC} (V)	25°C			-40°C TO 85°C		-55°C TO 125°C		UNITS
				MIN	TYP	MAX	MIN	MAX	MIN	MAX	
HC TYPES											
Clock Pulse Width	t _w	-	2	80	-	-	100	-	120	-	ns
			4.5	16	-	-	20	-	24	-	ns
			6	14	-	-	17	-	20	-	ns
MR Pulse Width	t _w	-	2	80	-	-	100	-	120	-	ns
			4.5	16	-	-	20	-	24	-	ns
			6	14	-	-	17	-	20	-	ns

CD54HC175, CD74HC175, CD54HCT175, CD74HCT175

Prerequisite For Switching Specifications (Continued)

PARAMETER	SYMBOL	TEST CONDITIONS	V _{CC} (V)	25°C			-40°C TO 85°C		-55°C TO 125°C		UNITS
				MIN	TYP	MAX	MIN	MAX	MIN	MAX	
Setup Time, Data to Clock	t _{SU}	-	2	80	-	-	100	-	120	-	ns
			4.5	16	-	-	20	-	24	-	ns
			6	14	-	-	17	-	20	-	ns
Hold Time, Data to Clock	t _H	-	2	5	-	-	5	-	5	-	ns
			4.5	5	-	-	5	-	5	-	ns
			6	5	-	-	5	-	5	-	ns
Removal Time, \overline{MR} to Clock	t _{REM}	-	2	5	-	-	5	-	5	-	ns
			4.5	5	-	-	5	-	5	-	ns
			6	5	-	-	5	-	5	-	ns
Clock Frequency	f _{MAX}	-	2	6	-	-	5	-	4	-	MHz
			4.5	30	-	-	25	-	20	-	MHz
			6	35	-	-	29	-	23	-	MHz

HCT TYPES

Clock Pulse Width	t _w	-	4.5	20	-	-	25	-	30	-	ns
\overline{MR} Pulse Width	t _w	-	4.5	20	-	-	25	-	30	-	ns
Setup Time Data to Clock	t _{SU}	-	4.5	20	-	-	25	-	30	-	ns
Hold Time Data to Clock	t _H	-	4.5	5	-	-	5	-	5	-	ns
Removal Time \overline{MR} to Clock	t _{REM}	-	4.5	5	-	-	5	-	5	-	ns
Clock Frequency	f _{MAX}	-	4.5	25	-	-	20	-	16	-	MHz

Switching Specifications Input t_r, t_f = 6ns

PARAMETER	SYMBOL	TEST CONDITIONS	V _{CC} (V)	25°C		-40°C TO 85°C	-55°C TO 125°C	UNITS		
				TYP	MAX	MAX	MAX			
Propagation Delay, Clock to Q or \overline{Q}	t _{PLH} , t _{PHL}	C _L = 50pF	2	-	175	220	265	ns		
			4.5	-	35	44	53	ns		
			6	-	30	37	45	ns		
		C _L = 15pF	5	14	-	-	-	ns		
			Propagation Delay, \overline{MR} to Q or \overline{Q}	C _L = 50pF	2	-	175	220	265	ns
					4.5	-	35	44	53	ns
6	-	30			37	45	ns			
C _L = 15pF	5	14	-	-	-	ns				
	Output Transition Times	C _L = 50pF	2	-	75	95	110	ns		
			4.5	-	15	19	22	ns		
6			-	13	16	19	ns			
Input Capacitance	C _{IN}	-	-	-	10	10	10	pF		
Power Dissipation Capacitance (Notes 3, 4)	C _{PD}	-	5	65	-	-	-	pF		

CD54HC175, CD74HC175, CD54HCT175, CD74HCT175

Switching Specifications Input $t_r, t_f = 6\text{ns}$ (Continued)

PARAMETER	SYMBOL	TEST CONDITIONS	V_{CC} (V)	25°C		-40°C TO 85°C	-55°C TO 125°C	UNITS
				TYP	MAX	MAX	MAX	
HCT TYPES								
Propagation Delay, Clock to Q or \bar{Q}	t_{PLH}, t_{PHL}	$C_L = 50\text{pF}$	4.5	-	33	41	50	ns
		$C_L = 15\text{pF}$	5	13	-	-	-	ns
Propagation Delay, \overline{MR} to Q or \bar{Q}	t_{PLH}, t_{PHL}	$C_L = 50\text{pF}$	4.5	-	35	44	53	ns
		$C_L = 15\text{pF}$	5	17	-	-	-	ns
Output Transition Times	t_{TLH}, t_{THL}	$C_L = 50\text{pF}$	4.5	-	15	19	22	ns
Input Capacitance	C_{IN}	-	-	-	10	10	10	pF
Power Dissipation Capacitance (Notes 3, 4)	C_{PD}	-	5	67	-	-	-	pF

NOTES:

- C_{PD} is used to determine the dynamic power consumption, per flip-flop.
- $P_D = V_{CC}^2 f_i + \sum (C_L V_{CC}^2 + f_O)$ where f_i = Input Frequency, f_O = Output Frequency, C_L = Output Load Capacitance, V_{CC} = Supply Voltage.

Test Circuits and Waveforms



FIGURE 1. HC SETUP TIMES, HOLD TIMES, REMOVAL TIME, AND PROPAGATION DELAY TIMES FOR EDGE TRIGGERED SEQUENTIAL LOGIC CIRCUITS

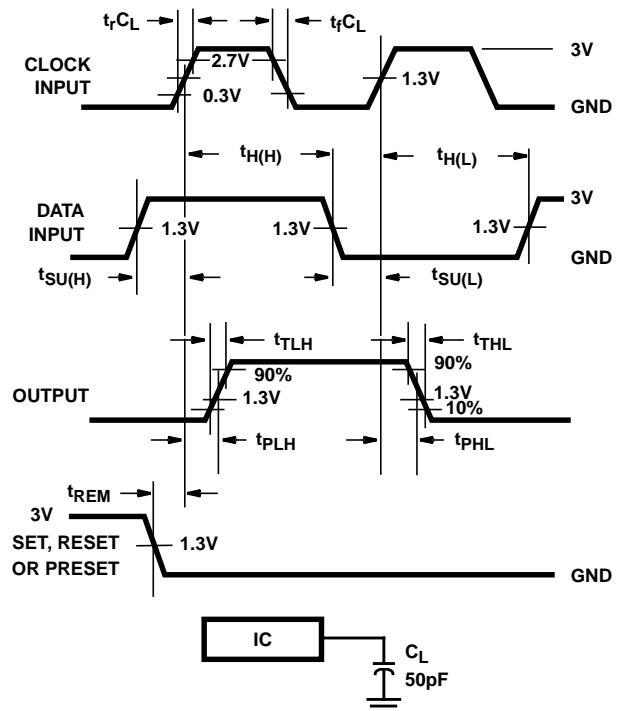

FIGURE 2. HCT SETUP TIMES, HOLD TIMES, REMOVAL TIME, AND PROPAGATION DELAY TIMES FOR EDGE TRIGGERED SEQUENTIAL LOGIC CIRCUITS