

The SN74LS16 is obsolete and is no longer supplied.

SN54LS06, SN74LS06, SN74LS16 HEX INVERTER BUFFERS/DRIVERS WITH OPEN-COLLECTOR HIGH-VOLTAGE OUTPUTS

SDLS020D – MAY 1990 – REVISED FEBRUARY 2003

- Convert TTL Voltage Levels to MOS Levels
- High Sink-Current Capability
- Input Clamping Diodes Simplify System Design
- Open-Collector Driver for Indicator Lamps and Relays
- Inputs Fully Compatible With Most TTL Circuits

description/ordering information

These hex inverter buffers/drivers feature high-voltage open-collector outputs to interface with high-level circuits (such as MOS), or for driving high-current loads, and also are characterized for use as inverter buffers for driving TTL inputs. The 'LS06 devices have a rated output voltage of 30 V, and the SN74LS16 has a rated output voltage of 15 V. The maximum sink current for the SN54LS06 is 30 mA, and for the SN74LS06 and SN74LS16 it is 40 mA.

These devices are compatible with most TTL families. Inputs are diode-clamped to minimize transmission effects, which simplifies design. Typical power dissipation is 175 mW, and average propagation delay time is 8 ns.

SN54LS06 . . . J PACKAGE
SN74LS06, SN74LS16 . . . D, DB, N, OR NS PACKAGE
(TOP VIEW)

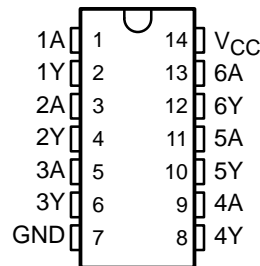

SN54LS06 . . . FK PACKAGE
(TOP VIEW)

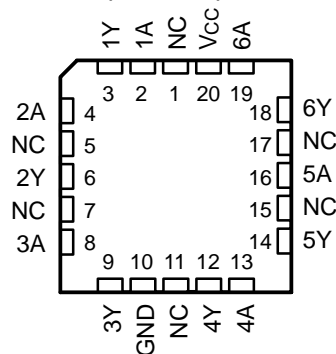

NC – No internal connection

ORDERING INFORMATION

TA	PACKAGE†		ORDERABLE PART NUMBER	TOP-SIDE MARKING
0°C to 70°C	PDIP – N	Tube	SN74LS06N	SN74LS06N
	SOIC – D	Tube	SN74LS06D	LS06
		Tape and reel	SN74LS06DR	
	SOP – NS	Tape and reel	SN74LS06NSR	74LS06
	SSOP – DB	Tape and reel	SN74LS06DBR	LS06
–55°C to 125°C	CDIP – J	Tube	SN54LS06J	SN54LS06J
		Tube	SNJ54LS06J	SNJ54LS06J
	LCCC – FK	Tube	SNJ54LS06FK	SNJ54LS06FK

† Package drawings, standard packing quantities, thermal data, symbolization, and PCB design guidelines are available at www.ti.com/sc/package.



Please be aware that an important notice concerning availability, standard warranty, and use in critical applications of Texas Instruments semiconductor products and disclaimers thereto appears at the end of this data sheet.

PRODUCTION DATA information is current as of publication date. Products conform to specifications per the terms of Texas Instruments standard warranty. Production processing does not necessarily include testing of all parameters.

 **TEXAS
INSTRUMENTS**

POST OFFICE BOX 655303 • DALLAS, TEXAS 75265

Copyright © 2003, Texas Instruments Incorporated
On products compliant to MIL-PRF-38535, all parameters are tested unless otherwise noted. On all other products, production processing does not necessarily include testing of all parameters.

SN54LS06, SN74LS06, SN74LS16 HEX INVERTER BUFFERS/DRIVERS WITH OPEN-COLLECTOR HIGH-VOLTAGE OUTPUTS

SDLS020D – MAY 1990 – REVISED FEBRUARY 2003

The SN74LS16 is obsolete
and is no longer supplied.

logic diagram (positive logic)

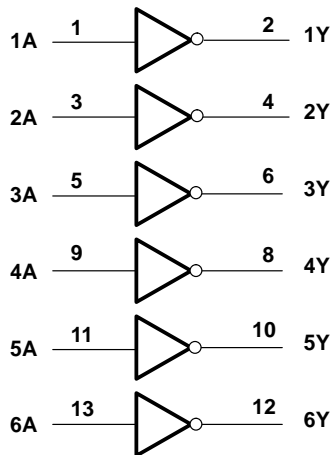

Pin numbers shown are for the D, DB, J, N, and NS packages.

schematic (each gate)

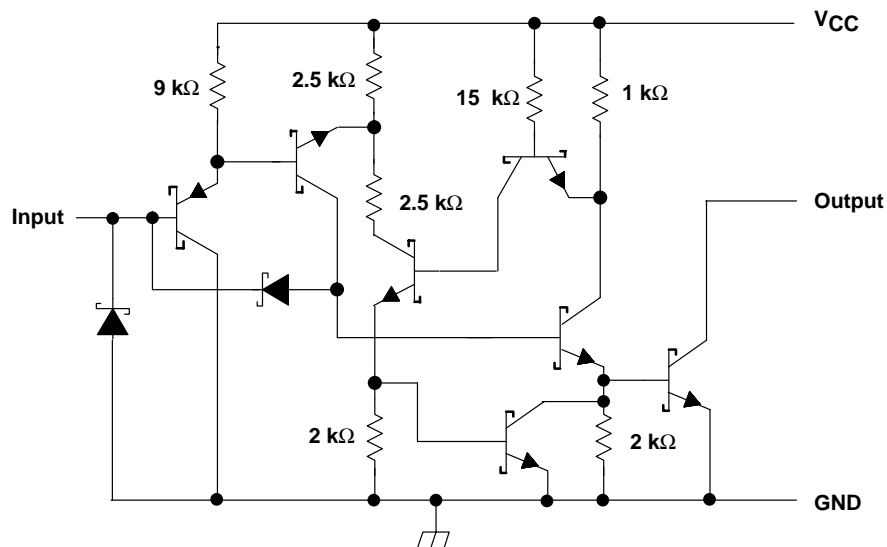

Resistor values shown are nominal.

The SN74LS16 is obsolete
and is no longer supplied.

SN54LS06, SN74LS06, SN74LS16 HEX INVERTER BUFFERS/DRIVERS WITH OPEN-COLLECTOR HIGH-VOLTAGE OUTPUTS

SDLS020D – MAY 1990 – REVISED FEBRUARY 2003

absolute maximum ratings over operating free-air temperature range (unless otherwise noted)†

Supply voltage, V_{CC}	7 V
Input voltage, V_I (see Note 1)	5.5 V
Output voltage, V_O (see Notes 1 and 2): SN54LS06, SN74LS06	30 V
SN74LS16	15 V
Package thermal impedance, θ_{JA} (see Note 3): D package	86°C/W
DB package	96°C/W
N package	80°C/W
NS package	76°C/W
Storage temperature range, T_{stg}	–65°C to 150°C

† Stresses beyond those listed under “absolute maximum ratings” may cause permanent damage to the device. These are stress ratings only, and functional operation of the device at these or any other conditions beyond those indicated under “recommended operating conditions” is not implied. Exposure to absolute-maximum-rated conditions for extended periods may affect device reliability.

- NOTES: 1. All voltage values are with respect to GND.
2. This is the maximum voltage that should be applied to any output when it is in the off state.
3. The package thermal impedance is calculated in accordance with JESD 51-7.

recommended operating conditions (see Note 4)

		SN54LS06			SN74LS06 SN74LS16			UNIT
		MIN	NOM	MAX	MIN	NOM	MAX	
V_{CC}	Supply voltage	4.5	5	5.5	4.75	5	5.25	V
V_{IH}	High-level input voltage	2			2			V
V_{IL}	Low-level input voltage			0.8			0.8	V
V_{OH}	High-level output voltage	'LS06			30			V
		SN74LS16			15			
I_{OL}	Low-level output current			30			40	mA
T_A	Operating free-air temperature	–55		125	0		70	°C

NOTE 4: All unused inputs of the device must be held at V_{CC} or GND to ensure proper device operation. Refer to the TI application report, *Implications of Slow or Floating CMOS Inputs*, literature number SCBA004.

electrical characteristics over recommended operating free-air temperature range (unless otherwise noted)

PARAMETER	TEST CONDITIONS‡	SN54LS06			SN74LS06 SN74LS16			UNIT	
		MIN	TYP§	MAX	MIN	TYP§	MAX		
V_{IK}	$V_{CC} = \text{MIN}$, $I_I = -12 \text{ mA}$			–1.5			–1.5	V	
I_{OH}	$V_{CC} = \text{MIN}$, $V_{IL} = 0.8 \text{ V}$	'LS06, $V_{OH} = 30 \text{ V}$			0.25			mA	
		SN74LS16, $V_{OH} = 15 \text{ V}$			0.25				
V_{OL}	$V_{CC} = \text{MIN}$, $V_{IH} = 2 \text{ V}$	$I_{OL} = 16 \text{ mA}$			0.25	0.4	0.25	0.4	V
		$I_{OL} = 30 \text{ mA}$			0.7				
		$I_{OL} = 40 \text{ mA}$			0.7				
I_I	$V_{CC} = \text{MAX}$, $V_I = 7 \text{ V}$			1			1	mA	
I_{IH}	$V_{CC} = \text{MAX}$, $V_I = 2.4 \text{ V}$			20			20	µA	
I_{IL}	$V_{CC} = \text{MAX}$, $V_I = 0.4 \text{ V}$			–0.2			–0.2	mA	
I_{CCH}	$V_{CC} = \text{MAX}$			18			18	mA	
I_{CCL}	$V_{CC} = \text{MAX}$			60			60	mA	

‡ For conditions shown as MIN or MAX, use the appropriate value specified under recommended operating conditions.

§ All typical values are at $V_{CC} = 5 \text{ V}$, and $T_A = 25^\circ\text{C}$.



SN54LS06, SN74LS06, SN74LS16
HEX INVERTER BUFFERS/DRIVERS
WITH OPEN-COLLECTOR HIGH-VOLTAGE OUTPUTS

SDLS020D – MAY 1990 – REVISED FEBRUARY 2003

The SN74LS16 is obsolete
and is no longer supplied.

switching characteristics, $V_{CC} = 5\text{ V}$, $T_A = 25^\circ\text{C}$ (see Figure 1)

PARAMETER	FROM (INPUT)	TO (OUTPUT)	TEST CONDITIONS	MIN	MAX	UNIT
t_{PLH}	A	Y	$R_L = 110\ \Omega$, $C_L = 15\ \text{pF}$	7	15	ns
t_{PHL}				10	20	



POST OFFICE BOX 655303 • DALLAS, TEXAS 75265

PARAMETER MEASUREMENT INFORMATION

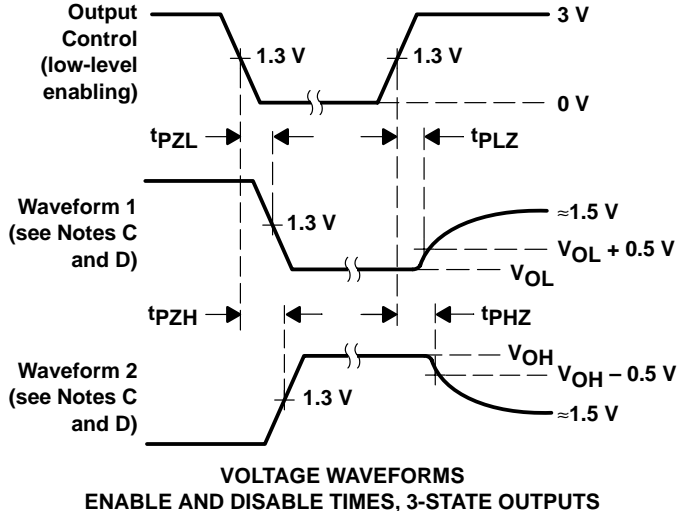
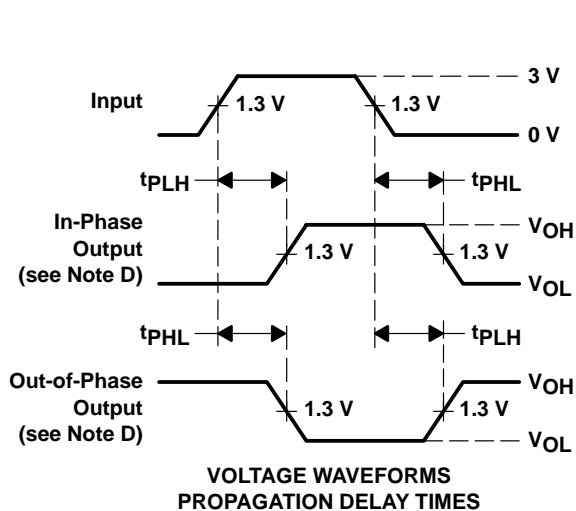
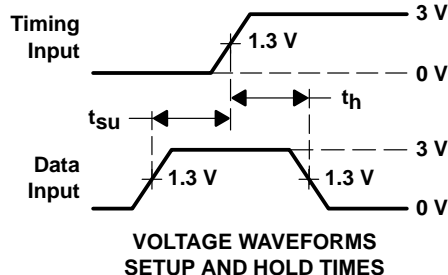
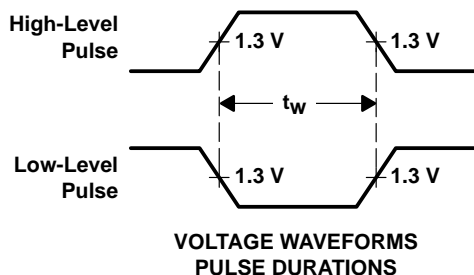
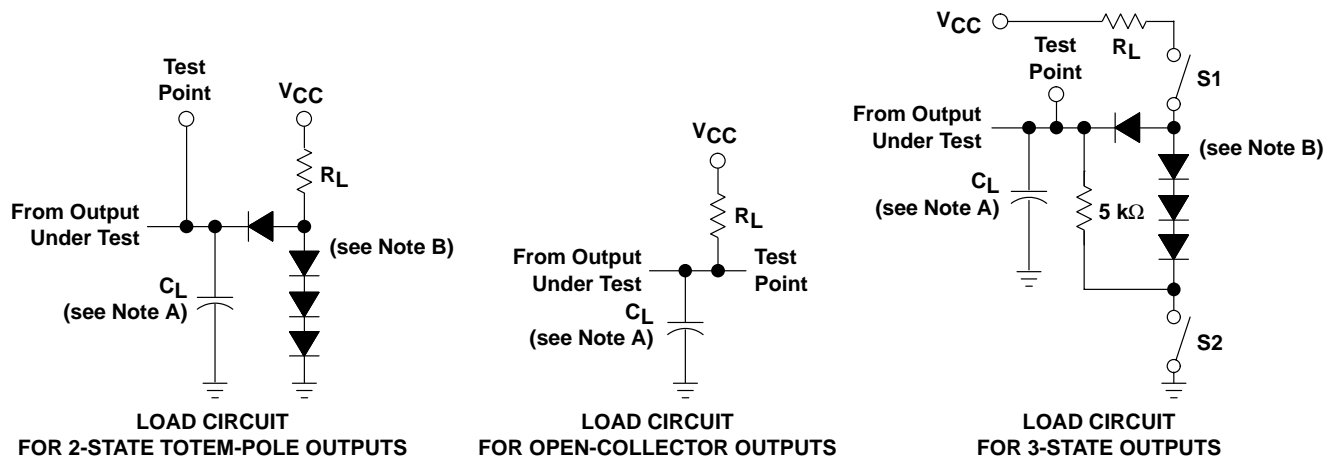

- NOTES:
- A. C_L includes probe and jig capacitance.
 - B. All diodes are 1N3064 or equivalent.
 - C. Waveform 1 is for an output with internal conditions such that the output is low except when disabled by the output control. Waveform 2 is for an output with internal conditions such that the output is high except when disabled by the output control.
 - D. S1 and S2 are closed for t_{PLH} , t_{PHL} , t_{PHZ} , and t_{PLZ} ; S1 is open and S2 is closed for t_{PZH} ; S1 is closed and S2 is open for t_{PZL} .
 - E. Phase relationships between inputs and outputs have been chosen arbitrarily for these examples.
 - F. All input pulses are supplied by generators having the following characteristics: PRR \leq 1 MHz, $Z_O \approx 50 \Omega$, $t_r \leq 1.5$ ns, $t_f \leq 2.6$ ns.
 - G. The outputs are measured one at a time with one input transition per measurement.

Figure 1. Load Circuits and Voltage Waveforms