

SN54LS673, SN54LS674, SN74LS673, SN74LS674 16-BIT SHIFT REGISTERS

SDLS195 – MARCH 1985 – REVISED MARCH 1988

'LS673

- 16-Bit Serial-In, Serial-Out Shift Register with 16-Bit Parallel-Out Storage Register
- Performs Serial-to-Parallel Conversion

'LS674

- 16-Bit Parallel-In, Serial-Out Shift Register
- Performs Parallel-to-Serial Conversion

description

SN54LS673, SN74LS673

The 'LS673 is a 16-bit shift register and a 16-bit storage register in a single 24-pin package. A three-state input/output (SER/Q15) port to the shift register allows serial entry and/or reading of data. The storage register is connected in a parallel data loop with the shift register and may be asynchronously cleared by taking the store-clear input low. The storage register may be parallel loaded with shift-register data to provide shift-register status via the parallel outputs. The shift register can be parallel loaded with the storage-register data upon command.

A high logic level at the chip-level (\overline{CS}) input disables both the shift-register clock and the storage register clock and places SER/Q15 in the high-impedance state. The store-clear function is not disabled by the chip select.

Caution must be exercised to prevent false clocking of either the shift register or the storage register via the chip-select input. The shift clock should be low during the low-to-high transition of chip select and the store clock should be low during the high-to-low transition of chip select.

SN54LS674, SN74LS674

The 'LS674 is a 16-bit parallel-in, serial-out shift register. A three-state input/output (SER/Q15) port provides access for entering a serial data or reading the shift-register word in a recirculating loop.

The device has four basic modes of operation:

- 1) Hold (do nothing)
- 2) Write (serially via input/output)
- 3) Read (serially)
- 4) Load (parallel via data inputs)

Low-to-high-level changes at the chip select input should be made only when the clock input is low to prevent false clocking.

SN54LS673 . . . J OR W PACKAGE SN74LS673 . . . DW OR N PACKAGE (TOP VIEW)

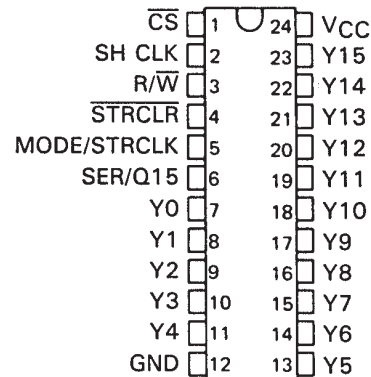

SN54LS673 . . . FK PACKAGE (TOP VIEW)

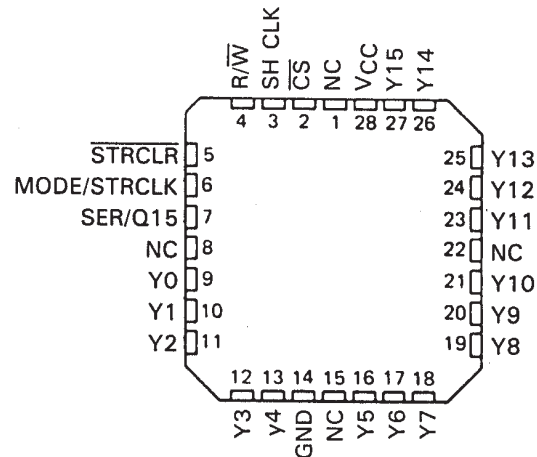

NC—No internal connection

SN54LS673, SN54LS674, SN74LS673, SN74LS674 16-BIT SHIFT REGISTERS

SDLS195 – MARCH 1985 – REVISED MARCH 1988

SN54LS674 . . . J OR W PACKAGE
SN74LS674 . . . DW OR N PACKAGE
(TOP VIEW)

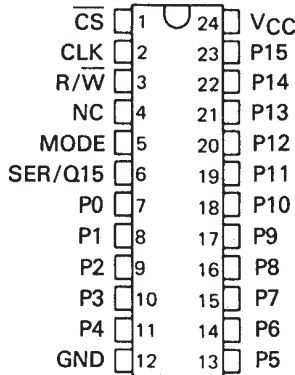

SN54LS674 . . . FK PACKAGE
(TOP VIEW)

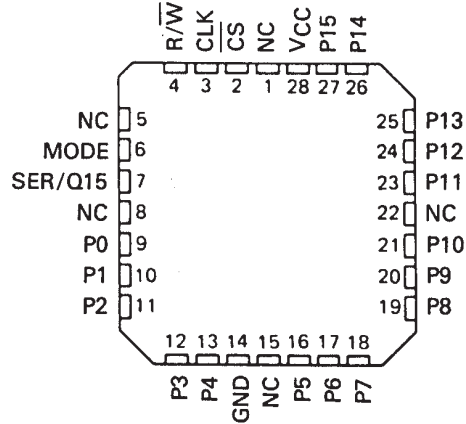

'LS673
FUNCTION TABLE

INPUTS					SER/ Q15	SHIFT REGISTER FUNCTIONS				STORAGE REGISTER FUNCTIONS	
CS	R/W	SH CLK	STRCLR	MODE/ STRCLK		SHIFT	READ FROM SERIAL OUTPUT	WRITE INTO SERIAL INPUT	PARALLEL LOAD	CLEAR	LOAD
H	X	X	X	X	Z	NO	NO	NO	NO		NO
X	X	X	L	X						YES	
L	L	↓	X	X	Z	YES	NO	YES	NO		
L	H	X	X	X	Q15		YES	NO			NO
L	H	↓	X	L	Q14n	YES	YES	NO	NO		NO
L	H	↓	L	H	L	NO	YES		YES	YES	NO
L	H	↓	H	H	Y15n	NO	YES		YES	NO	NO
L	L	X	H	↑	Z		NO		NO	NO	YES

'LS674 FUNCTION TABLE

INPUTS				SER/ Q15	OPERATION
CS	R/W	MODE	CLK		
H	X	X	X	Z	Do nothing
L	L	X	↓	Z	Shift and write (serial load)
L	H	L	↓	Q14n	Shift and read
L	H	H	↓	P15	Parallel load

H = high level (steady state)
L = low level (steady state)
↑ = transition from low to high level
↓ = transition from high to low level
X = irrelevant (any input including transitions)
Z = high impedance, input mode
Q14n = content of 14th bit of the shift register before the most recent ↓ transition of the clock.
Q15 = present content of 15th bit of the shift register
Y15n = content of the 15th bit of the storage register before the most recent ↓ transition of the clock.
P15 = level of input P15

SN54LS673, SN54LS674, SN74LS673, SN74LS674 16-BIT SHIFT REGISTERS

SDLS195 – MARCH 1985 – REVISED MARCH 1988

logic symbols†



†These symbols are in accordance with ANSI/IEEE Std. 91-1984 and IEC Publication 617-12. Pin numbers shown are for DW, J, N, and W packages.

SN54LS673, SN54LS674, SN74LS673, SN74LS674 16-BIT SHIFT REGISTERS

SDLS195 – MARCH 1985 – REVISED MARCH 1988

functional block diagrams

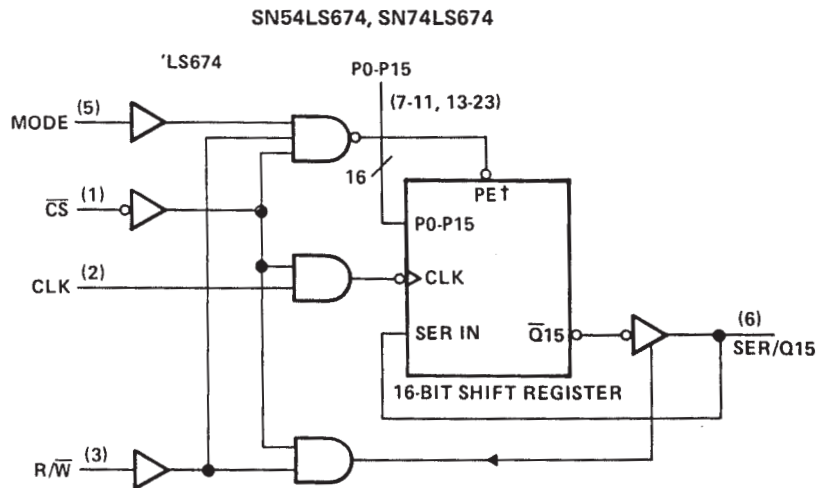
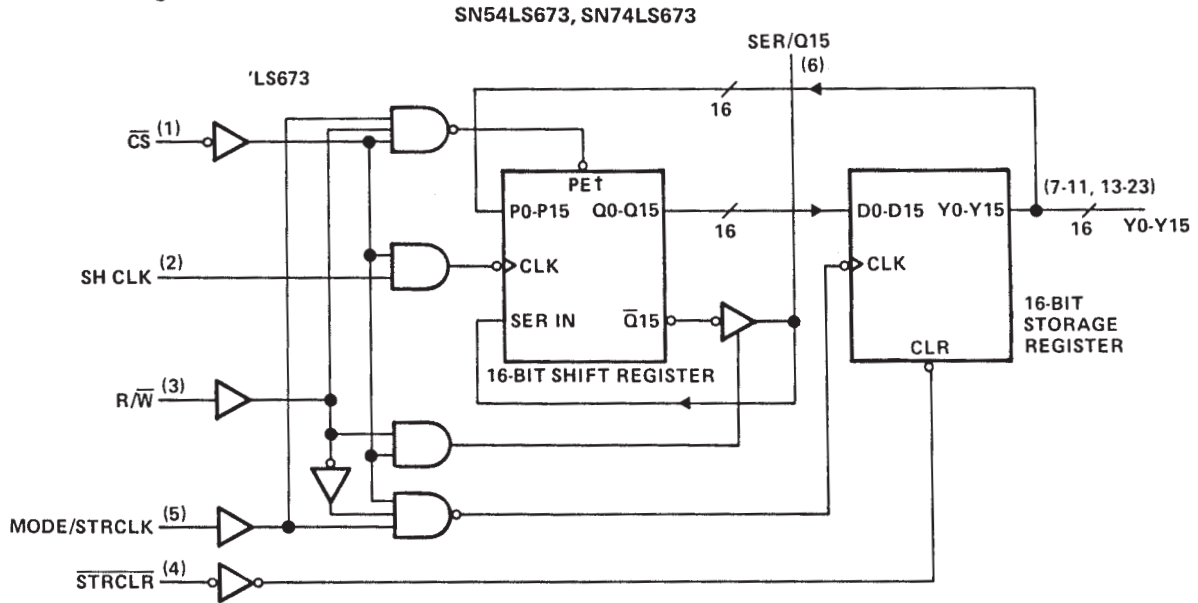

†When PE is active, data is synchronously parallel loaded into the shift registers from the 16 P inputs and no shifting takes place. Pin numbers shown are for DW, J, N, and W packages.

SN54LS673, SN54LS674, SN74LS673, SN74LS674 16-BIT SHIFT REGISTERS

SDLS195 – MARCH 1985 – REVISED MARCH 1988

schematics of inputs and outputs

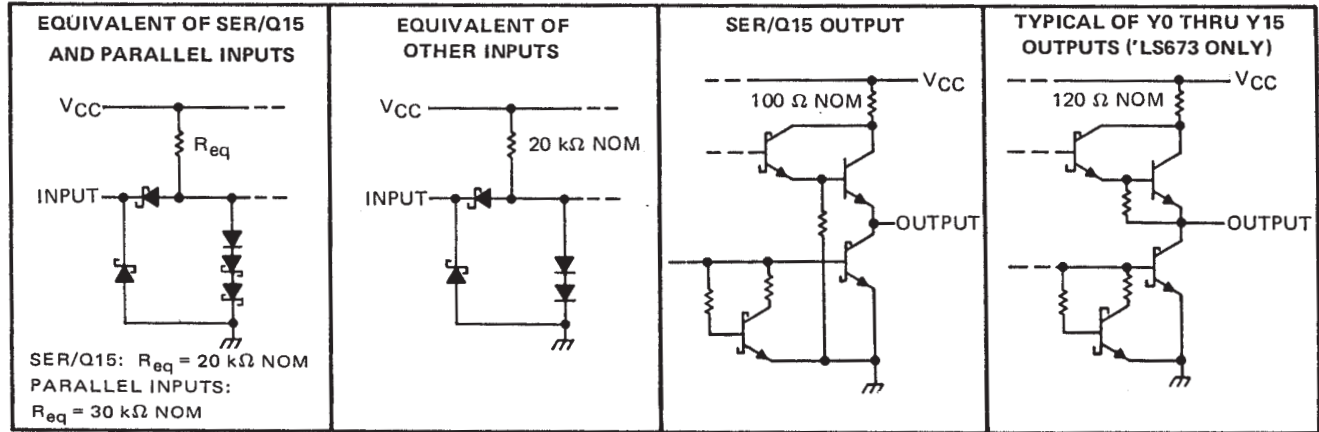

absolute maximum ratings over operating free-air temperature range (unless otherwise noted)

Supply voltage, V_{CC} (see Note 1)	7 V
Input voltage: SER/Q15	5.5 V
All others	7 V
Off-state output voltage	5.5 V
Operating free-air temperature range: SN54LS673, SN54LS674	-55°C to 125°C
SN74LS673, SN74LS674	0°C to 70°C
Storage temperature range	-65°C to 150°C

NOTE 1. Voltage values are with respect to network ground terminal.

recommended operating conditions

		SN54LS'			SN74LS'			UNIT
		MIN	NOM	MAX	MIN	NOM	MAX	
V_{CC}	Supply voltage	4.5	5	5.5	4.75	5	5.25	V
I_{OH}	High-level output current	SER/Q15		-1	Y0 thru Y15		-2.6	mA
		Y0 thru Y15		-0.4	Y0 thru Y15		-0.4	
I_{OL}	Low-level output current	SER/Q15		12	Y0 thru Y15		24	mA
		Y0 thru Y15		4	Y0 thru Y15		8	
f_{clock}	Clock frequency	0		20	0		20	MHz
$t_{w(clock)}$	Width of clock input pulse	20			20			ns
$t_{w(clear)}$	Width of clear input pulse	20			20			ns
t_{su}	Setup time	SER/Q15		20	Y0 thru Y15		20	ns
		P0 thru P15		20	Y0 thru Y15		20	
		Mode		35	Y0 thru Y15		35	
		$R/\overline{W}, \overline{CS}$		35	Y0 thru Y15		35	
		SH CLK ↓ to Mode/STR CLK ↑ See Note 2		25	Y0 thru Y15		25	
t_h	Hold time	SER/Q15		0	Y0 thru Y15		0	ns
		P0 thru P15	'LS673	0	Y0 thru Y15		0	
			'LS674	5.0	Y0 thru Y15		5.0	
Mode		0	Y0 thru Y15		0			
T_A	Operating free-air temperature	-55		125	0		70	°C

NOTE 2: This setup time ensures the storage register will see stable data from the shift register.



SN54LS673, SN54LS674, SN74LS673, SN74LS674

16-BIT SHIFT REGISTERS

SDLS195 – MARCH 1985 – REVISED MARCH 1988

electrical characteristics over recommended operating free-air temperature range (unless otherwise noted)

PARAMETER		TEST CONDITIONS†	SN54LS'		SN74LS'		UNIT
			MIN	TYP‡	MAX	MIN	
V _{IH}	High-level input voltage		2		2		V
V _{IL}	Low-level input voltage			0.7		0.8	V
V _{IK}	Input clamp voltage	V _{CC} = MIN, I _I = -18 mA		-1.5		-1.5	V
V _{OH}	High-level output voltage	SER/Q15	V _{CC} = MIN, V _{IH} = 2 V,		2.4	3.1	V
		Y0 thru Y15¶	V _{IL} = V _{ILmax} , I _{OH} = MAX		2.5	3.4	
V _{OL}	Low-level output voltage	SER/Q15	V _{CC} = MIN, V _{IH} = 2 V,	I _{OL} = 12 mA	0.25	0.4	V
				I _{OL} = 24 mA		0.35	
		Y0 thru Y15¶	V _{IL} = V _{ILmax}	I _{OL} = 4 mA	0.25	0.4	
				I _{OL} = 8 mA		0.35	
I _{OZH}	Off-state output current, high-level voltage applied	SER/Q15	V _{CC} = MAX, V _{IH} = 2 V, V _{IL} = V _{ILmax} , V _O = 2.7 V	40		40	μA
I _{OZL}	Off-state output current, low-level voltage applied	SER/Q15	V _{CC} = MAX, V _{IH} = 2 V, V _{IL} = V _{ILmax} , V _O = 0.4 V	-0.4		-0.4	mA
I _I	Input current at maximum input voltage	SER/Q15	V _{CC} = MAX	V _I = 5.5 V		0.1	mA
		Others		V _I = 7 V		0.1	
I _{IH}	High-level input current	SER/Q15	V _{CC} = MAX, V _I = 2.7 V			40	μA
		Others				20	
I _{IL}	Low-level input current		V _{CC} = MAX, V _I = 0.4 V			-0.4	mA
I _{OS}	Short-circuit output current§	SER/Q15	V _{CC} = MAX		-30	-130	mA
		Y0 thru Y15¶			-20	-100	
I _{CC}	Supply current	'LS673	V _{CC} = MAX		50	80	mA
		'LS674			25	40	

† For conditions shown as MIN or MAX use the appropriate value specified under recommended operating conditions.

‡ All typical values are at V_{CC} = 5 V, T_A = 25°C.

§ Not more than one output should be shorted at a time, and duration of the short circuit should not exceed one second.

¶ 'LS673 only.

switching characteristics, V_{CC} = 5 V, T_A = 25°C, see note 2

PARAMETER	'LS673		'LS674		TEST CONDITIONS	MIN	TYP	MAX	UNIT
	FROM	TO	FROM	TO					
f _{max}	SH CLK	SER/Q15	CLK	SER/Q15	R _L = 667 Ω, C _L = 45 pF	20	28		MHz
t _{PHL}	STRCLR	Y0 thru Y15					25	40	ns
t _{PLH}	MODE/ STRCLK	Y0 thru Y15			R _L = 2 kΩ, C _L = 15 pF		28	45	
t _{PHL}							30	45	ns
t _{PLH}	SH CLK	SER/Q15	CLK	SER/Q15	R _L = 667 Ω, C _L = 45 pF		21	33	
t _{PHL}							26	40	ns
t _{PZH}	CS, R/W	SER/Q15	CS, R/W	SER/Q15	R _L = 667 Ω, C _L = 45 pF		30	45	
t _{PZL}							30	45	ns
t _{PHZ}	CS, R/W	SER/Q15	CS, R/W	SER/Q15	R _L = 667 Ω, C _L = 5 pF		25	40	
t _{PLZ}							25	40	ns

NOTE 2: Load circuits and voltage waveforms are shown in Section 1.

