

SN54279, SN54LS279A, SN74279, SN74LS279A QUADRUPLE S-R LATCHES

SDLS093 - DECEMBER 1983 - REVISED MARCH 1988

- Package Options Include Plastic "Small Outline" Packages, Ceramic Chip Carriers and Flat Packages, and Plastic and Ceramic DIPs

- Dependable Texas Instruments Quality and Reliability

description

The '279 offers 4 basic \bar{S} - \bar{R} flip-flop latches in one 16-pin, 300-mil package. Under conventional operation, the \bar{S} - \bar{R} inputs are normally held high. When the \bar{S} input is pulsed low, the Q output will be set high. When \bar{R} is pulsed low, the Q output will be reset low. Normally, the \bar{S} - \bar{R} inputs should not be taken low simultaneously. The Q output will be unpredictable in this condition.

FUNCTION TABLE
(each latch)

| INPUTS | | OUTPUT |
|-------------|-----------|--------------|
| \bar{S} † | \bar{R} | Q |
| H | H | Q_0 |
| L | H | H |
| H | L | L |
| L | L | H^\ddagger |

H = high level L = low level

†For latches with double S inputs:

Q_0 = the level of Q before the indicated input conditions were established.

‡This configuration is nonstable: that is, it may not persist when the \bar{S} and \bar{R} inputs return to their inactive (high) level.

H = both \bar{S} inputs high

L = one or both \bar{S} inputs low

logic diagram (positive logic)

(latches 1 and 3)

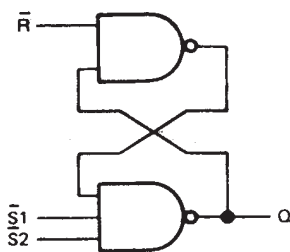

(latches 2 and 4)

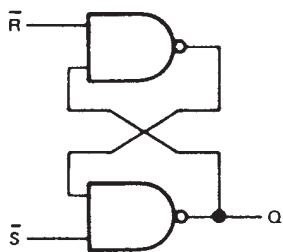

SN54279, SN54LS279A . . . J OR W PACKAGE
SN74279 . . . N PACKAGE
SN74LS279A . . . D OR N PACKAGE
(TOP VIEW)

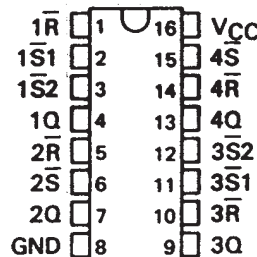

SN54LS279A . . . FK PACKAGE
(TOP VIEW)

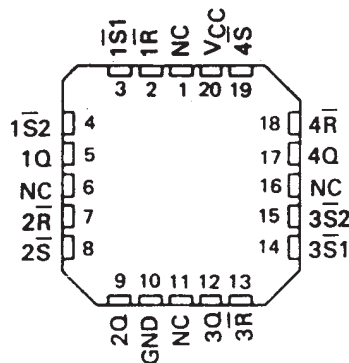

NC - No internal connection

logic symbol[§]

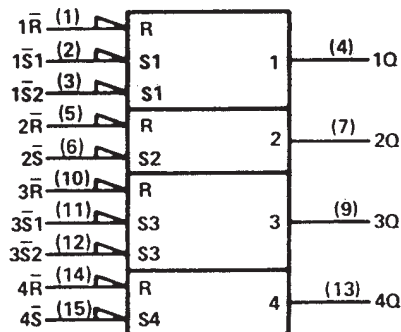

[§]This symbol is in accordance with ANSI/IEEE Std. 91-1984 and IEC Publication 617-12.

Pin numbers shown are for D, J, N, and W packages.

PRODUCTION DATA information is current as of publication date. Products conform to specifications per the terms of Texas Instruments standard warranty. Production processing does not necessarily include testing of all parameters.

 **TEXAS
INSTRUMENTS**

POST OFFICE BOX 655303 • DALLAS, TEXAS 75265

Copyright © 1988, Texas Instruments Incorporated

SN54279, SN54LS279A, SN74279, SN74LS279A QUADRUPLE S-R LATCHES

SDLS093 – DECEMBER 1983 – REVISED MARCH 1988

schematics of inputs and outputs

'279 CIRCUITS

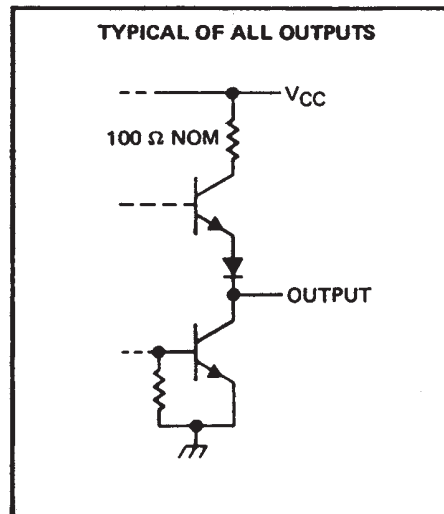
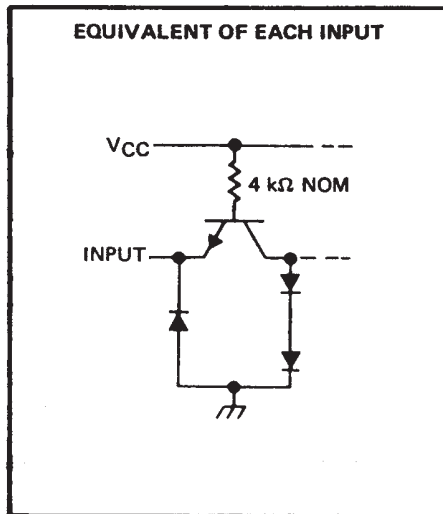

'LS279A CIRCUITS

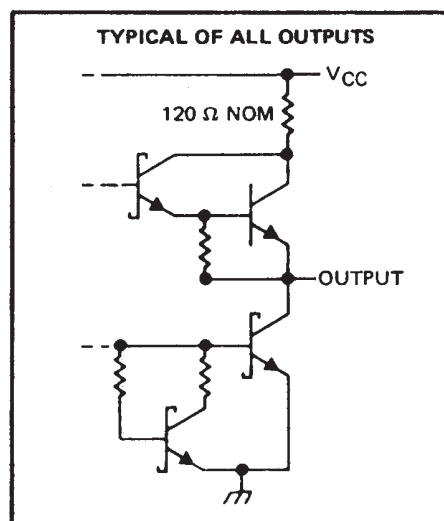
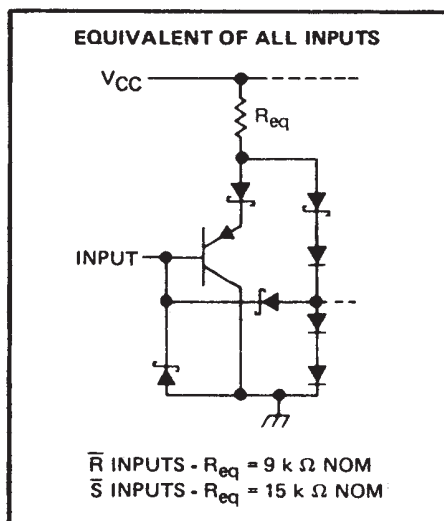

absolute maximum ratings over operating free-air temperature range (unless otherwise noted)

| | |
|---|-------------------|
| Supply voltage, V_{CC} (see Note 1) | 7 V |
| Input voltage: '279 | 5.5 V |
| 'LS279A | 7 V |
| Operating free-air temperature range: SN54' TYPES | - 55° C to 125° C |
| SN74' TYPES | 0° C to 70° C |
| Storage temperature range | - 65° C to 150° C |

NOTE 1: Voltage values are with respect to network ground terminal.



POST OFFICE BOX 655303 • DALLAS, TEXAS 75265

SN54279, SN54LS279A, SN74279, SN74LS279A QUADRUPLE S-R LATCHES

SDLS093 – DECEMBER 1983 – REVISED MARCH 1988

recommended operating conditions

| | SN54279 | | | SN74279 | | | UNIT |
|---|---------|-----|------|---------|-----|------|------|
| | MIN | NOM | MAX | MIN | NOM | MAX | |
| V _{CC} Supply voltage | 4.5 | 5 | 5.5 | 4.75 | 5 | 5.25 | V |
| V _{IH} High-level input voltage | 2 | | | 2 | | | V |
| V _{IL} Low-level input voltage | | | 0.8 | | | 0.8 | V |
| I _{OH} High-level output current | | | -0.8 | | | -0.8 | mA |
| I _{OL} Low-level output current | | | 16 | | | 16 | mA |
| t _w Pulse duration, low | 20 | | | 20 | | | ns |
| T _A Operating free-air temperature | -55 | | 125 | 0 | | 70 | °C |

electrical characteristics over recommended operating free-air temperature range (unless otherwise noted)

| PARAMETER | TEST CONDITIONS† | SN54279 | | | SN74279 | | | UNIT |
|-------------------|---|---------|------|------|---------|------|------|------|
| | | MIN | TYP‡ | MAX | MIN | TYP‡ | MAX | |
| V _{IK} | V _{CC} = MIN, I _I = -12 mA | | | -1.5 | | | -1.5 | V |
| V _{OH} | V _{CC} = MIN, V _{IL} = 0.8 V, I _{OH} = -0.8 mA | 2.4 | 3.4 | | 2.4 | 3.4 | | V |
| V _{OL} | V _{CC} = MIN, V _{IH} = 2 V, I _{OL} = 16 mA | | 0.2 | 0.4 | | 0.2 | 0.4 | V |
| I _I | V _{CC} = MAX, V _I = 5.5 V | | | 1 | | | 1 | mA |
| I _{IH} | V _{CC} = MAX, V _I = 2.4 V | | | 40 | | | 40 | μA |
| I _{IL} | V _{CC} = MAX, V _I = 0.4 V | | | -1.6 | | | -1.6 | mA |
| I _{OS} § | V _{CC} = MAX | -18 | | -55 | -18 | | -57 | mA |
| I _{CC} | V _{CC} = MAX, See Note 2 | | 18 | 30 | | 18 | 30 | mA |

† For conditions shown as MIN or MAX, use the appropriate value specified under recommended operating conditions.

‡ All typical values are at V_{CC} = 5 V, T_A = 25°C.

§ Not more than one output should be shorted at a time.

NOTE 2: I_{CC} is measured with all R inputs grounded, all S inputs at 4.5 V, and all outputs open.

switching characteristics, V_{CC} = 5 V, T_A = 25°C (see note 3)

| PARAMETER | FROM (INPUT) | TO (OUTPUT) | TEST CONDITIONS | MIN | TYP | MAX | UNIT |
|------------------|--------------|-------------|--|-----|-----|-----|------|
| t _{PLH} | S | Q | R _L = 400 Ω, C _L = 15 pF | | 12 | 22 | ns |
| t _{PHL} | S | Q | | | 9 | 15 | |
| t _{PHL} | R | Q | | | 15 | 27 | |

NOTE 3: Load circuits and voltage waveforms are shown in Section 1.

SN54279, SN54LS279A, SN74279, SN74LS279A QUADRUPLE S-R LATCHES

SDLS093 – DECEMBER 1983 – REVISED MARCH 1988

recommended operating conditions

| | SN54LS279A | | | SN74LS279A | | | UNIT |
|---|------------|-----|------|------------|-----|------|------|
| | MIN | NOM | MAX | MIN | NOM | MAX | |
| V _{CC} Supply voltage | 4.5 | 5 | 5.5 | 4.75 | 5 | 5.25 | V |
| V _{IH} High-level input voltage | 2 | | | 2 | | | V |
| V _{IL} Low-level input voltage | | | 0.7 | | | 0.8 | V |
| I _{OH} High-level output current | | | -0.4 | | | -0.4 | mA |
| I _{OL} Low-level output current | | | 4 | | | 8 | mA |
| t _w Pulse duration, low | 20 | | | 20 | | | ns |
| T _A Operating free-air temperature | -55 | | 125 | 0 | | 70 | °C |

electrical characteristics over recommended operating free-air temperature range (unless otherwise noted)

| PARAMETER | TEST CONDITIONS† | SN54LS279A | | | SN74LS279A | | | UNIT |
|-------------------|---|------------|------|------|------------|------|------|------|
| | | MIN | TYP‡ | MAX | MIN | TYP‡ | MAX | |
| V _{IK} | V _{CC} = MIN, I _I = -18 mA | | | -1.5 | | | -1.5 | V |
| V _{OH} | V _{CC} = MIN, V _{IL} = MAX, I _{OH} = -0.4 mA | 2.5 | 3.4 | | 2.7 | 3.4 | | V |
| V _{OL} | V _{CC} = MIN, V _{IH} = 2 V, I _{OL} = 4 mA | | 0.25 | 0.4 | | 0.25 | 0.4 | V |
| | V _{CC} = MIN, V _{IH} = 2 V, I _{OL} = 8 mA | | | | | 0.25 | 0.5 | |
| I _I | V _{CC} = MAX, V _I = 7 V | | | 0.1 | | | 0.1 | mA |
| I _{IH} | V _{CC} = MAX, V _I = 2.7 V | | | 20 | | | 20 | μA |
| I _{IL} | V _{CC} = MAX, V _I = 0.4 V | | | -0.2 | | | -0.2 | mA |
| I _{OS} § | V _{CC} = MAX | -20 | | -100 | -20 | | -100 | mA |
| I _{CC} | V _{CC} = MAX, See note 2 | | 3.8 | 7 | | 3.8 | 7 | mA |

† For conditions shown as MIN or MAX, use the appropriate value specified under recommended operating conditions.

‡ All typical values are at V_{CC} = 5 V, T_A = 25°C.

§ Not more than one output should be shorted at a time, and the duration of the short-circuit should be less than one second.

NOTE 2: I_{CC} is measured with all R inputs grounded, all S inputs at 4.5 V, and all outputs open.

switching characteristics, V_{CC} = 5 V, T_A = 25°C (see note 3)

| PARAMETER | FROM (INPUT) | TO (OUTPUT) | TEST CONDITIONS | MIN | TYP | MAX | UNIT |
|------------------|--------------|-------------|---|-----|-----|-----|------|
| t _{PLH} | S | Q | R _L = 2 kΩ, C _L = 15 pF | | 12 | 22 | ns |
| t _{PHL} | | | | | 13 | 21 | |
| t _{PHL} | R | Q | | | 15 | 27 | ns |

NOTE 3: Load circuits and voltage waveforms are shown in Section 1.

