

SN54376, SN74376 QUADRUPLE J-K FLIP-FLOPS

SDLS104 – OCTOBER 1976 – REVISED MARCH 1988

- Four J-K Flip-Flops in a Single Package . . . Can Reduce FF Package Count by 50%
- Common Positive-Edge-Triggered Clocks with Hysteresis . . . Typically 200 mV
- Fully Buffered Outputs
- Typical Clock Input Frequency . . . 45 MHz

SN54376 . . . J PACKAGE
SN74376 . . . N PACKAGE
(TOP VIEW)

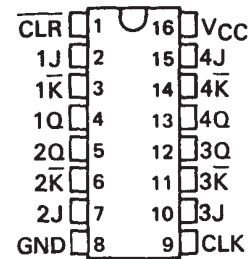

description

These quadruple TTL J-K flip-flops incorporate a number of third-generation IC features that can simplify system design and reduce flip-flop package count by as much as 50%. They feature hysteresis at the clock input, fully buffered outputs, and direct clear capability. The positive-edge-triggered SN54376 and SN74376 are directly compatible with most Series 54/74 MSI registers.

The SN54376 is characterized for operation over the full military temperature range of -55°C to 125°C ; the SN74376 is characterized for operation from 0°C to 70°C .

FUNCTION TABLE (EACH FLIP-FLOP)

COMMON INPUTS		INPUTS		OUTPUT
CLEAR	CLOCK	J	\bar{K}	Q
L	X	X	X	L
H	\uparrow	L	H	Q_0
H	\uparrow	H	H	H
H	\uparrow	L	L	L
H	\uparrow	H	L	TOGGLE
H	L	X	X	Q_0

logic symbol

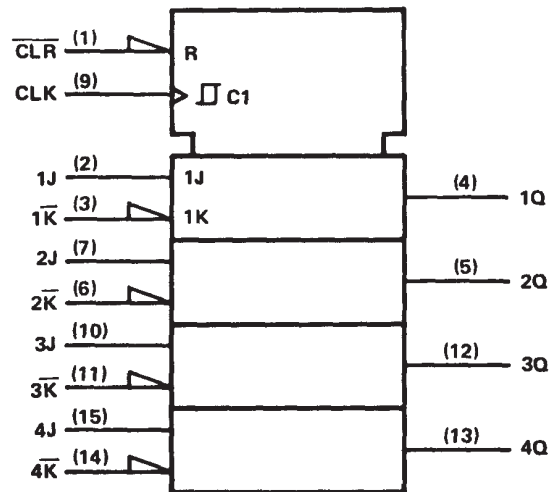

[†]This symbol is in accordance with ANSI/IEEE Std. 91-1984 and IEC Publication 617-12.

schematics of inputs and outputs

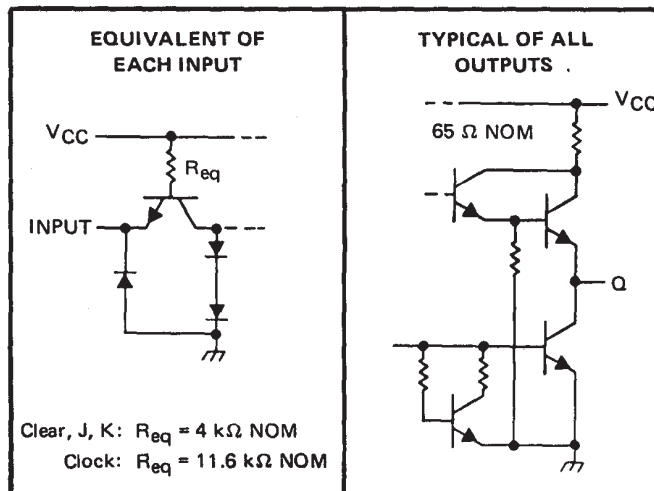

Clear, J, K: $R_{eq} = 4 \text{ k}\Omega \text{ NOM}$
Clock: $R_{eq} = 11.6 \text{ k}\Omega \text{ NOM}$

Resistor values shown are nominal.

PRODUCTION DATA information is current as of publication date. Products conform to specifications per the terms of Texas Instruments standard warranty. Production processing does not necessarily include testing of all parameters.

**TEXAS
INSTRUMENTS**

POST OFFICE BOX 655303 • DALLAS, TEXAS 75265

Copyright © 1988, Texas Instruments Incorporated

SN54376, SN74376 QUADRUPLE J-K FLIP-FLOPS

SDLS104 – OCTOBER 1976 – REVISED MARCH 1988

absolute maximum ratings over operating free-air temperature range (unless otherwise noted)

Supply voltage, V_{CC} (see Note 1)	7 V
Input voltage	5.5 V
Operating free-air temperature range: SN54376	-55°C to 125°C
SN74376	0°C to 70°C
Storage temperature range	-65°C to 150°C

NOTE 1: Voltage values are with respect to network ground terminals.

recommended operating conditions

		SN54376			SN74376			UNIT
		MIN	NOM	MAX	MIN	NOM	MAX	
Supply voltage, V_{CC}		4.5	5	5.5	4.75	5	5.25	V
High-level output current, I_{OH}				-800			-800	μ A
Low-level output current, I_{OL}				16			16	mA
Clock frequency		0		30	0		30	MHz
Pulse width, t_W	Clock high	22			22			ns
	Clock low	12			12			
	Preset or clear low	12			12			
Setup time, t_{su}	J, \bar{K} inputs	0†			0†			ns
	Clear inactive state	10†			10†			
Input hold time, t_h		20†			20†			ns
Operating free-air temperature, T_A		-55		125	0		70	°C

†‡The arrow indicates the edge of the clock pulse used for reference: † for the rising edge, ‡ for the falling edge.

electrical characteristics over recommended operating free-air temperature range (unless otherwise noted)

PARAMETER		TEST CONDITIONS†	MIN	TYP‡	MAX	UNIT
V_{IH}	High-level input voltage		2			V
V_{IL}	Low-level input voltage				0.8	V
V_{IK}	Input clamp voltage	$V_{CC} = \text{MIN}, I_I = -12 \text{ mA}$			-1.5	V
V_{OH}	High-level output voltage	$V_{CC} = \text{MIN}, V_{IH} = 2 \text{ V}, V_{IL} = 0.8 \text{ V}, I_{OH} = -800 \mu\text{A}$	2.4	3.4		V
V_{OL}	Low-level output voltage	$V_{CC} = \text{MIN}, V_{IH} = 2 \text{ V}, V_{IL} = 0.8 \text{ V}, I_{OL} = 16 \text{ mA}$		0.2	0.4	V
I_I	Input current at maximum input voltage	$V_{CC} = \text{MAX}, V_I = 5.5 \text{ V}$			1	mA
I_{IH}	High-level input current	$V_{CC} = \text{MAX}, V_I = 2.4 \text{ V}$			40	μ A
I_{IL}	Low-level input current	$V_{CC} = \text{MAX}, V_I = 0.4 \text{ V}$			-1.6	mA
I_{OS}	Short-circuit output current§	$V_{CC} = \text{MAX}$	-30		-85	mA
I_{CC}	Supply current	$V_{CC} = \text{MAX}$		52	74	mA

† For conditions shown as MIN or MAX, use the appropriate value specified under recommended operating conditions.

‡ All typical values are at $V_{CC} = 5 \text{ V}, T_A = 25^\circ\text{C}$.

§ Not more than one output should be shorted at a time.

switching characteristics, $V_{CC} = 5 \text{ V}, T_A = 25^\circ\text{C}$

PARAMETER		TEST CONDITIONS	MIN	TYP	MAX	UNIT
f_{max}	Maximum clock frequency	$C_L = 15 \text{ pF}, R_L = 400 \Omega,$ See Note 2	30	45		MHz
t_{PHL}	Propagation delay time, high-to-low-level output from clear			17	30	ns
t_{PLH}	Propagation delay time, low-to-high-level output from clock			22	35	ns
t_{PHL}	Propagation delay time, high-to-low-level output from clock			24	35	ns

NOTE 2: Load circuits and voltage waveforms are shown in Section 1.



POST OFFICE BOX 655303 • DALLAS, TEXAS 75265