

Features

- **Buffered Inputs and Outputs**
- **Four Operating Modes**
- **Typical Propagation Delay of 15ns at $V_{CC} = 5V$, $C_L = 15pF$, $T_A = 25^\circ C$**
- **Fanout (Over Temperature Range)**
 - **Standard Outputs 10 LSTTL Loads**
 - **Bus Driver Outputs 15 LSTTL Loads**
- **Wide Operating Temperature Range . . . $-55^\circ C$ to $125^\circ C$**
- **Balanced Propagation Delay and Transition Times**
- **Significant Power Reduction Compared to LSTTL Logic ICs**
- **HC Types**
 - **2V to 6V Operation**
 - **High Noise Immunity: $N_{IL} = 30\%$, $N_{IH} = 30\%$ of V_{CC} at $V_{CC} = 5V$**
- **HCT Types**
 - **4.5V to 5.5V Operation**
 - **Direct LSTTL Input Logic Compatibility, $V_{IL} = 0.8V$ (Max), $V_{IH} = 2V$ (Min)**
 - **CMOS Input Compatibility, $I_I \leq 1\mu A$ at V_{OL} , V_{OH}**

Description

The 'HC259 and 'HCT259 Addressable Latch features the low-power consumption associated with CMOS circuitry and has speeds comparable to low-power Schottky.

This latches three active modes and one reset mode. When both the Latch Enable (\overline{LE}) and Master Reset (\overline{MR}) inputs are low (8-line Demultiplexer mode) the output of the addressed latch follows the Data input and all other outputs are forced low. When both \overline{MR} and \overline{LE} are high (Memory Mode), all outputs are isolated from the Data input, i.e., all latches hold the last data presented before the \overline{LE} transition from low to high. A condition of \overline{LE} low and \overline{MR} high (Addressable Latch mode) allows the addressed latch's output to follow the data input; all other latches are unaffected. The Reset mode (all outputs low) results when \overline{LE} is high and \overline{MR} is low.

Ordering Information

PART NUMBER	TEMP. RANGE (°C)	PACKAGE
CD54HC259F3A	-55 to 125	16 Ld CERDIP
CD54HCT259F3A	-55 to 125	16 Ld CERDIP
CD74HC259E	-55 to 125	16 Ld PDIP
CD74HC259M	-55 to 125	16 Ld SOIC
CD74HC259MT	-55 to 125	16 Ld SOIC
CD74HC259M96	-55 to 125	16 Ld SOIC
CD74HCT259E	-55 to 125	16 Ld PDIP
CD74HCT259M	-55 to 125	16 Ld SOIC
CD74HCT259MT	-55 to 125	16 Ld SOIC
CD74HCT259M96	-55 to 125	16 Ld SOIC

NOTE: When ordering, use the entire part number. The suffix 96 denotes tape and reel. The suffix T denotes a small-quantity reel of 250.

CD54HC259, CD74HC259, CD54HCT259, CD74HCT259

Pinout

CD54HC259, CD54HCT259
(CERDIP)
CD74HC259, CD74HCT259
(PDIP, SOIC)
TOP VIEW

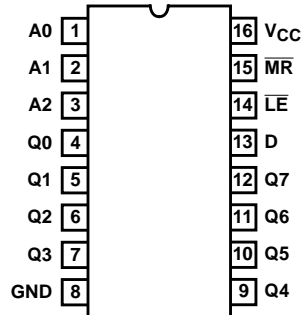

Functional Diagram

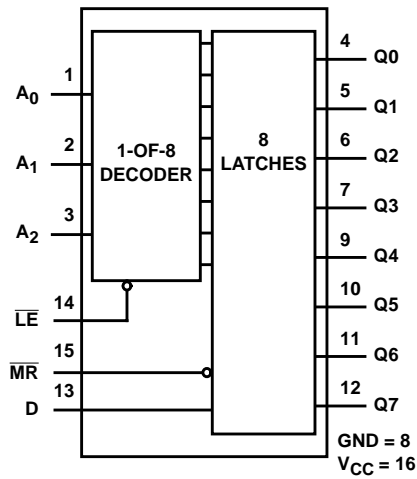

TRUTH TABLE

INPUTS		OUTPUT OF ADDRESS LATCH	EACH OTHER OUTPUT	FUNCTION
\overline{MR}	\overline{LE}			
H	L	D	Q_{i0}	Addressable Latch
H	H	Q_{i0}	Q_{i0}	Memory
L	L	D	L	8-Line Demultiplexer
L	H	L	L	Reset

H = High Voltage Level

L = Low Voltage Level

D = The level at the data input

Q_{i0} = The level of Q_i ($i = 0, 1...7$, as appropriate) before the indicated steady-state input conditions were established.

LATCH SELECTION TABLE

SELECT INPUTS			LATCH ADDRESSED
A2	A1	A0	
L	L	L	0
L	L	H	1
L	H	L	2
L	H	H	3
H	L	L	4
H	L	H	5
H	H	L	6
H	H	H	7

CD54HC259, CD74HC259, CD54HCT259, CD74HCT259

Absolute Maximum Ratings

DC Supply Voltage, V_{CC}	-0.5V to 7V
DC Input Diode Current, I_{IK}	
For $V_I < -0.5V$ or $V_I > V_{CC} + 0.5V$	$\pm 20mA$
DC Output Diode Current, I_{OK}	
For $V_O < -0.5V$ or $V_O > V_{CC} + 0.5V$	$\pm 20mA$
DC Drain Current, per Output, I_O	
For $-0.5V < V_O < V_{CC} + 0.5V$	$\pm 25mA$
DC Output Source or Sink Current per Output Pin, I_O	
For $V_O > -0.5V$ or $V_O < V_{CC} + 0.5V$	$\pm 25mA$
DC V_{CC} or Ground Current, I_{CC} or I_{GND}	$\pm 50mA$

Thermal Information

Thermal Resistance (Typical, Note 1)	θ_{JA} ($^{\circ}C/W$)
E (PDIP) Package	67
M (SOIC) Package	73
Maximum Junction Temperature	150 $^{\circ}C$
Maximum Storage Temperature Range	-65 $^{\circ}C$ to 150 $^{\circ}C$
Maximum Lead Temperature (Soldering 10s)	300 $^{\circ}C$ (SOIC - Lead Tips Only)

Operating Conditions

Temperature Range, T_A	-55 $^{\circ}C$ to 125 $^{\circ}C$
Supply Voltage Range, V_{CC}	
HC Types2V to 6V
HCT Types	4.5V to 5.5V
DC Input or Output Voltage, V_I, V_O	0V to V_{CC}
Input Rise and Fall Time	
2V	1000ns (Max)
4.5V	500ns (Max)
6V	400ns (Max)

CAUTION: Stresses above those listed in "Absolute Maximum Ratings" may cause permanent damage to the device. This is a stress only rating and operation of the device at these or any other conditions above those indicated in the operational sections of this specification is not implied.

NOTE:

1. The package thermal impedance is calculated in accordance with JESD 51-7.

DC Electrical Specifications

PARAMETER	SYMBOL	TEST CONDITIONS		V_{CC} (V)	25 $^{\circ}C$			-40 $^{\circ}C$ TO 85 $^{\circ}C$		-55 $^{\circ}C$ TO 125 $^{\circ}C$		UNITS	
		V_I (V)	I_O (mA)		MIN	TYP	MAX	MIN	MAX	MIN	MAX		
HC TYPES													
High Level Input Voltage	V_{IH}	-	-	2	1.5	-	-	1.5	-	1.5	-	V	
				4.5	3.15	-	-	3.15	-	3.15	-	V	
				6	4.2	-	-	4.2	-	4.2	-	V	
Low Level Input Voltage	V_{IL}	-	-	2	-	-	0.5	-	0.5	-	0.5	V	
				4.5	-	-	1.35	-	1.35	-	1.35	V	
				6	-	-	1.8	-	1.8	-	1.8	V	
High Level Output Voltage CMOS Loads	V_{OH}	V_{IH} or V_{IL}	-0.02	2	1.9	-	-	1.9	-	1.9	-	V	
				4.5	4.4	-	-	4.4	-	4.4	-	V	
				6	5.9	-	-	5.9	-	5.9	-	V	
High Level Output Voltage TTL Loads	V_{OH}	V_{IH} or V_{IL}	-	-	-	-	-	-	-	-	-	V	
				-4	4.5	3.98	-	-	3.84	-	3.7	-	V
				-5.2	6	5.48	-	-	5.34	-	5.2	-	V
Low Level Output Voltage CMOS Loads	V_{OL}	V_{IH} or V_{IL}	0.02	2	-	-	0.1	-	0.1	-	0.1	V	
				4.5	-	-	0.1	-	0.1	-	0.1	V	
				6	-	-	0.1	-	0.1	-	0.1	V	
Low Level Output Voltage TTL Loads	V_{OL}	V_{IH} or V_{IL}	-	-	-	-	-	-	-	-	-	V	
				4	4.5	-	-	0.26	-	0.33	-	0.4	V
				5.2	6	-	-	0.26	-	0.33	-	0.4	V
Input Leakage Current	I_I	V_{CC} or GND	-	6	-	-	± 0.1	-	± 1	-	± 1	μA	

CD54HC259, CD74HC259, CD54HCT259, CD74HCT259

DC Electrical Specifications (Continued)

PARAMETER	SYMBOL	TEST CONDITIONS		V _{CC} (V)	25°C			-40°C TO 85°C		-55°C TO 125°C		UNITS
		V _I (V)	I _O (mA)		MIN	TYP	MAX	MIN	MAX	MIN	MAX	
Quiescent Device Current	I _{CC}	V _{CC} or GND	0	6	-	-	8	-	80	-	160	μA
HCT TYPES												
High Level Input Voltage	V _{IH}	-	-	4.5 to 5.5	2	-	-	2	-	2	-	V
Low Level Input Voltage	V _{IL}	-	-	4.5 to 5.5	-	-	0.8	-	0.8	-	0.8	V
High Level Output Voltage CMOS Loads	V _{OH}	V _{IH} or V _{IL}	-0.02	4.5	4.4	-	-	4.4	-	4.4	-	V
High Level Output Voltage TTL Loads			-4	4.5	3.98	-	-	3.84	-	3.7	-	V
Low Level Output Voltage CMOS Loads	V _{OL}	V _{IH} or V _{IL}	0.02	4.5	-	-	0.1	-	0.1	-	0.1	V
Low Level Output Voltage TTL Loads			4	4.5	-	-	0.26	-	0.33	-	0.4	V
Input Leakage Current	I _I	V _{CC} and GND	0	5.5	-	-	±0.1	-	±1	-	±1	μA
Quiescent Device Current	I _{CC}	V _{CC} or GND	0	5.5	-	-	8	-	80	-	160	μA
Additional Quiescent Device Current Per Input Pin: 1 Unit Load	ΔI _{CC} (Note 2)	V _{CC} -2.1	-	4.5 to 5.5	-	100	360	-	450	-	490	μA

NOTE:

- For dual-supply systems theoretical worst case (V_I = 2.4V, V_{CC} = 5.5V) specification is 1.8mA.

HCT Input Loading Table

INPUT	UNIT LOADS
A0 - A2, \overline{LE}	1.5
D	1.2
MR	0.75

NOTE: Unit Load is ΔI_{CC} limit specified in DC Electrical Table, e.g., 360μA max at 25°C.

Prerequisite for Switching Specifications

PARAMETER	SYMBOL	V _{CC} (V)	25°C			-40°C TO 85°C			-55°C TO 125°C			UNITS
			MIN	TYP	MAX	MIN	TYP	MAX	MIN	TYP	MAX	
HC TYPES												
Pulse Width \overline{LE}	t _{WL}	2	70	-	-	90	-	-	105	-	-	ns
		4.5	14	-	-	18	-	-	21	-	-	ns
		6	12	-	-	15	-	-	18	-	-	ns

CD54HC259, CD74HC259, CD54HCT259, CD74HCT259

Prerequisite for Switching Specifications (Continued)

PARAMETER	SYMBOL	V _{CC} (V)	25°C			-40°C TO 85°C			-55°C TO 125°C			UNITS
			MIN	TYP	MAX	MIN	TYP	MAX	MIN	TYP	MAX	
MR	t _{WL}	2	70	-	-	90	-	-	105	-	-	ns
		4.5	14	-	-	18	-	-	21	-	-	ns
		6	12	-	-	15	-	-	18	-	-	ns
Setup Time D to \overline{LE} A to \overline{LE}	t _{SU}	2	80	-	-	100	-	-	120	-	-	ns
		4.5	16	-	-	20	-	-	24	-	-	ns
		6	14	-	-	17	-	-	20	-	-	ns
Hold Time D to \overline{LE} A to \overline{LE}	t _H	2	0	-	-	0	-	-	0	-	-	ns
		4.5	0	-	-	0	-	-	0	-	-	ns
		6	0	-	-	0	-	-	0	-	-	ns
HCT TYPES												
Pulse Width \overline{LE} MR	t _{WL}	4.5	18	-	-	23	-	-	27	-	-	ns
Setup Time D to \overline{LE} A to \overline{LE}	t _{SU}	4.5	17	-	-	21	-	-	26	-	-	ns
Hold Time D to \overline{LE} A to \overline{LE}	t _H	4.5	0	-	-	0	-	-	0	-	-	ns

Switching Specifications C_L = 50pF, Input t_r, t_f = 6ns

PARAMETER	SYMBOL	TEST CONDITIONS	V _{CC} (V)	25°C			-40°C TO 85°C		-55°C TO 125°C		UNITS
				MIN	TYP	MAX	MIN	MAX	MIN	MAX	
HC TYPES											
Propagation Delay D to Q	t _{PHL}	C _L = 50pF	2	-	-	185	-	230	-	280	ns
			4.5	-	-	37	-	46	-	56	ns
		C _L = 15pF	5	-	15	-	-	-	-	-	ns
		C _L = 50pF	6	-	-	31	-	39	-	48	ns
\overline{LE} to Q	t _{PHL}	C _L = 50pF	2	-	-	170	-	215	-	255	ns
			4.5	-	-	34	-	43	-	51	ns
		C _L = 15pF	5	-	14	-	-	-	-	-	ns
		C _L = 50pF	6	-	-	29	-	37	-	43	ns

CD54HC259, CD74HC259, CD54HCT259, CD74HCT259

Switching Specifications $C_L = 50\text{pF}$, Input t_r , $t_f = 6\text{ns}$ (Continued)

PARAMETER	SYMBOL	TEST CONDITIONS	V_{CC} (V)	25°C			-40°C TO 85°C		-55°C TO 125°C		UNITS
				MIN	TYP	MAX	MIN	MAX	MIN	MAX	
A to Q	t_{PHL}	$C_L = 50\text{pF}$	2	-	-	185	-	230	-	280	ns
			4.5	-	-	37	-	46	-	56	ns
		$C_L = 15\text{pF}$	5	-	15	-	-	-	-	-	ns
		$C_L = 50\text{pF}$	6	-	-	31	-	39	-	48	ns
\overline{MR} to Q	t_{PHL}, t_{PLH}	$C_L = 50\text{pF}$	2	-	-	155	-	195	-	235	ns
			4.5	-	-	31	-	39	-	47	ns
		$C_L = 15\text{pF}$	5	-	13	-	-	-	-	-	ns
		$C_L = 50\text{pF}$	6	-	-	26	-	33	-	40	ns
Output Transition Time	t_{THL}, t_{TLH}	$C_L = 50\text{pF}$	2	-	-	75	-	95	-	110	ns
			4.5	-	-	15	-	19	-	22	ns
			6	-	-	13	-	16	-	19	ns
Power Dissipation Capacitance (Notes 3, 4)	C_{PD}	$C_L = 15\text{pF}$	5	-	21	-	-	-	-	-	pF
Input Capacitance	C_I	$C_L = 50\text{pF}$	-	10	-	10	-	10	-	10	pF

HCT TYPES

Propagation Delay D to Q	t_{PHL}, t_{PLH}	$C_L = 50\text{pF}$	4.5	-	-	39	-	49	-	59	ns
			$C_L = 15\text{pF}$	5	-	16	-	-	-	-	-
\overline{LE} to Q	t_{PHL}, t_{PLH}	$C_L = 50\text{pF}$	4.5	-	-	38	-	48	-	57	ns
			$C_L = 15\text{pF}$	5	-	16	-	-	-	-	-
A to Q	t_{PHL}, t_{PLH}	$C_L = 50\text{pF}$	4.5	-	-	41	-	51	-	61	ns
			$C_L = 15\text{pF}$	5	-	17	-	-	-	-	-
\overline{MR} to Q	t_{PHL}, t_{PLH}	$C_L = 50\text{pF}$	4.5	-	-	39	-	49	-	59	ns
			$C_L = 15\text{pF}$	5	-	16	-	-	-	-	-
Power Dissipation Capacitance (Notes 3, 4)	C_{PD}	$C_L = 15\text{pF}$	5	-	22	-	-	-	-	-	pF
Input Capacitance	C_I	$C_L = 50\text{pF}$	-	10	-	10	-	10	-	10	pF
Output Transition Time	t_{THL}, t_{TLH}	$C_L = 50\text{pF}$	4.5	-	-	15	-	19	-	22	ns

NOTES:

- C_{PD} is used to determine the dynamic power consumption, per package.
- $P_D = C_{PD} V_{CC}^2 f_i + \sum C_L V_{CC}^2 f_O$ where f_i = Input Frequency, f_O = Output Frequency, C_L = Output Load Capacitance, V_{CC} = Supply Voltage.

Test Circuits and Waveforms

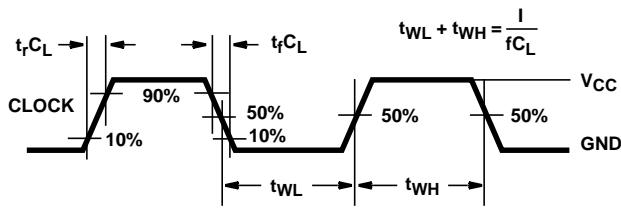

NOTE: Outputs should be switching from 10% V_{CC} to 90% V_{CC} in accordance with device truth table. For f_{MAX} , input duty cycle = 50%.

FIGURE 1. HC CLOCK PULSE RISE AND FALL TIMES AND PULSE WIDTH

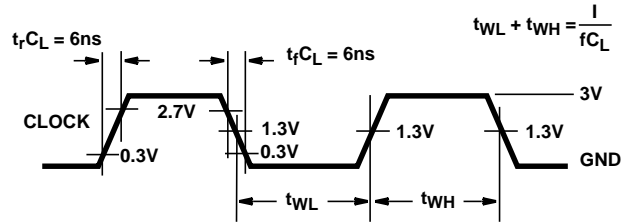

NOTE: Outputs should be switching from 10% V_{CC} to 90% V_{CC} in accordance with device truth table. For f_{MAX} , input duty cycle = 50%.

FIGURE 2. HCT CLOCK PULSE RISE AND FALL TIMES AND PULSE WIDTH

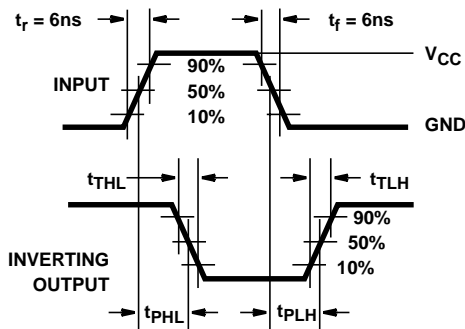

FIGURE 3. HC TRANSITION TIMES AND PROPAGATION DELAY TIMES, COMBINATION LOGIC

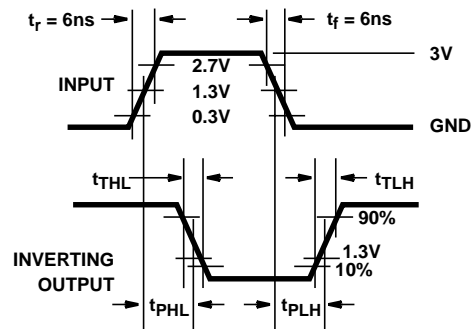

FIGURE 4. HCT TRANSITION TIMES AND PROPAGATION DELAY TIMES, COMBINATION LOGIC

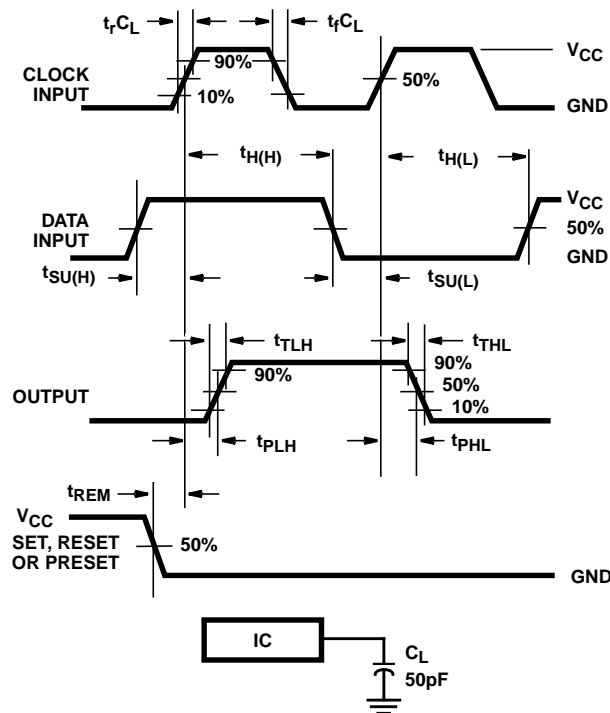

FIGURE 5. HC SETUP TIMES, HOLD TIMES, REMOVAL TIME, AND PROPAGATION DELAY TIMES FOR EDGE TRIGGERED SEQUENTIAL LOGIC CIRCUITS

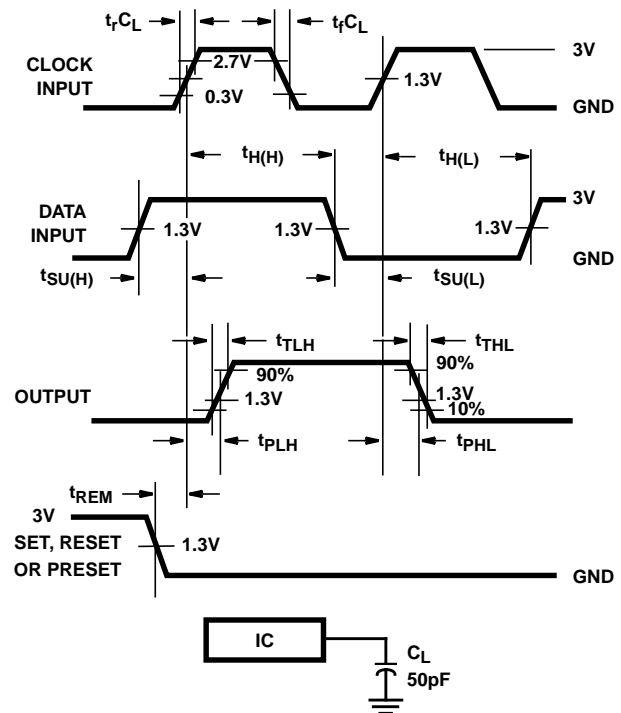

FIGURE 6. HCT SETUP TIMES, HOLD TIMES, REMOVAL TIME, AND PROPAGATION DELAY TIMES FOR EDGE TRIGGERED SEQUENTIAL LOGIC CIRCUITS

Test Circuits and Waveforms (Continued)

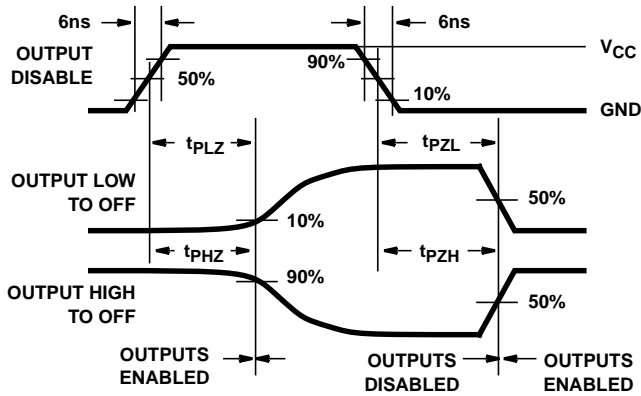

FIGURE 7. HC THREE-STATE PROPAGATION DELAY WAVEFORM



FIGURE 8. HCT THREE-STATE PROPAGATION DELAY WAVEFORM



NOTE: Open drain waveforms t_{PLZ} and t_{PZL} are the same as those for three-state shown on the left. The test circuit is Output $R_L = 1k\Omega$ to V_{CC} , $C_L = 50pF$.

FIGURE 9. HC AND HCT THREE-STATE PROPAGATION DELAY TEST CIRCUIT