

SN54LS137, SN74LS137 3-LINE TO 8-LINE DECODERS/DEMULTIPLEXERS WITH ADDRESS LATCHES

SDLS132 - JUNE 1978 - REVISED MARCH 1988

- Combines Decoder and 3-Bit Address Latch
- Incorporates 2 Enable Inputs to Simplify Cascading
- Low Power Dissipation . . . 65 mW Typ

description

The 'LS137 is a three-line to eight-line decoder/demultiplexer with latches on the three address inputs. When the latch-enable input (\overline{GL}) is low, the 'LS137 acts as a decoder/demultiplexer. When \overline{GL} goes from low to high, the address present at the select inputs (A, B, and C) is stored in the latches. Further address changes are ignored as long as \overline{GL} remains high. The output enable controls, G1 and $\overline{G2}$, control the state of the outputs independently of the select or latch-enable inputs. All of the outputs are high unless G1 is high and $\overline{G2}$ is low. The 'LS137 is ideally suited for implementing glitch-free decoders in strobed (stored-address) applications in bus-oriented systems.

SN54LS137 . . . J OR W PACKAGE

SN74LS137 . . . D OR N PACKAGE

(TOP VIEW)

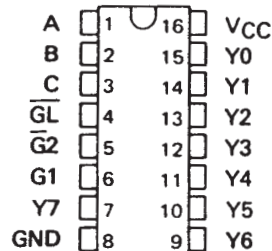

SN54LS137 . . .FK PACKAGE

(TOP VIEW)

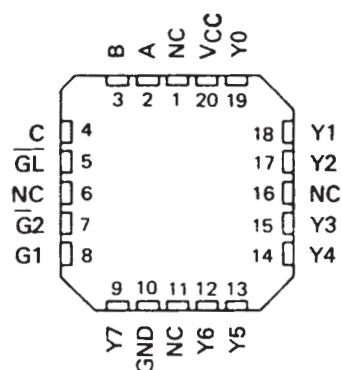

NC - No internal connection

schematics of inputs and outputs

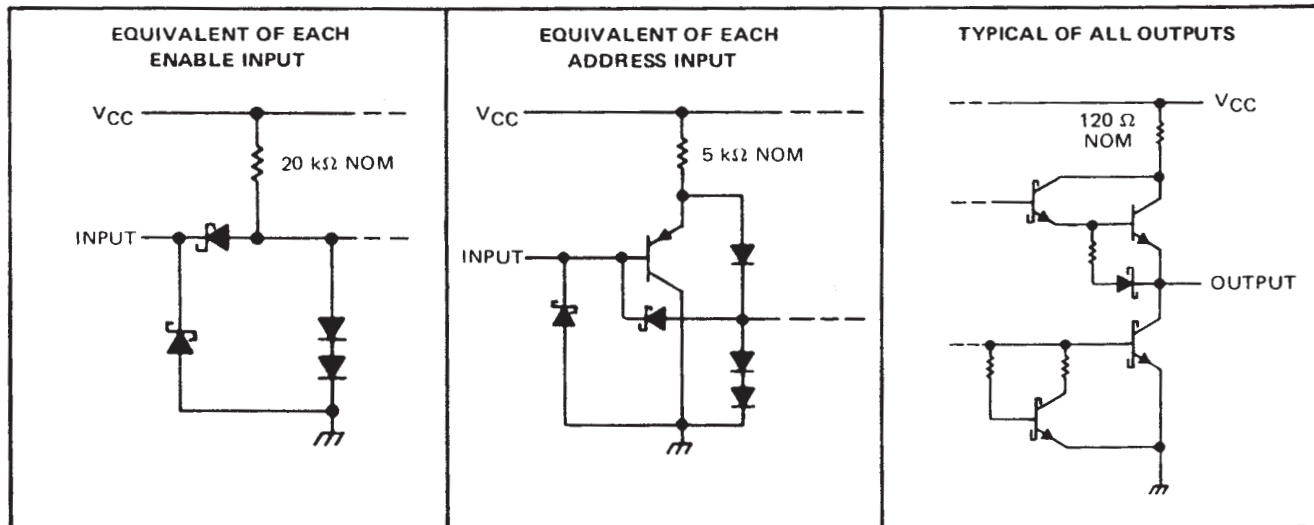

PRODUCTION DATA information is current as of publication date. Products conform to specifications per the terms of Texas Instruments standard warranty. Production processing does not necessarily include testing of all parameters.



POST OFFICE BOX 655303 • DALLAS, TEXAS 75265

Copyright © 1988, Texas Instruments Incorporated

SN54LS137, SN74LS137 3-LINE TO 8-LINE DECODERS/DEMULTIPLEXERS WITH ADDRESS LATCHES

SDLS132 – JUNE 1978 – REVISED MARCH 1988

logic symbols†

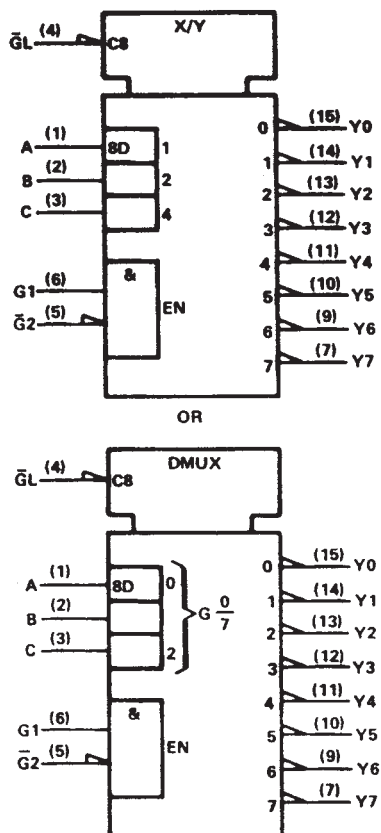

FUNCTION TABLE

INPUTS				OUTPUTS									
ENABLE		SELECT											
GL	G1	G2	C	B	A	Y0	Y1	Y2	Y3	Y4	Y5	Y6	Y7
X	X	H	X	X	X	H	H	H	H	H	H	H	H
X	L	X	X	X	X	H	H	H	H	H	H	H	H
L	H	L	L	L	L	L	H	H	H	H	H	H	H
L	H	L	L	L	H	H	L	H	H	H	H	H	H
L	H	L	L	H	L	H	H	L	H	H	H	H	H
L	H	L	L	H	H	H	H	H	L	H	H	H	H
L	H	L	H	L	H	H	H	H	H	L	H	H	H
L	H	L	H	H	L	H	H	H	H	H	L	H	H
L	H	L	H	H	H	H	H	H	H	H	H	L	H
L	H	L	H	H	H	H	H	H	H	H	H	H	L
H	H	L	X	X	X	Output corresponding to stored address, L; all others, H							

H = high level, L = low level, X = irrelevant

†These symbols are in accordance with ANSI/IEEE Std 91-1984 and IEC Publication 617-12.

Pin numbers shown are for D, J, N, and W packages.

SN54LS137, SN74LS137 3-LINE TO 8-LINE DECODERS/DEMULTIPLEXERS WITH ADDRESS LATCHES

SDLS132 - JUNE 1978 - REVISED MARCH 1988

logic diagram (positive logic)

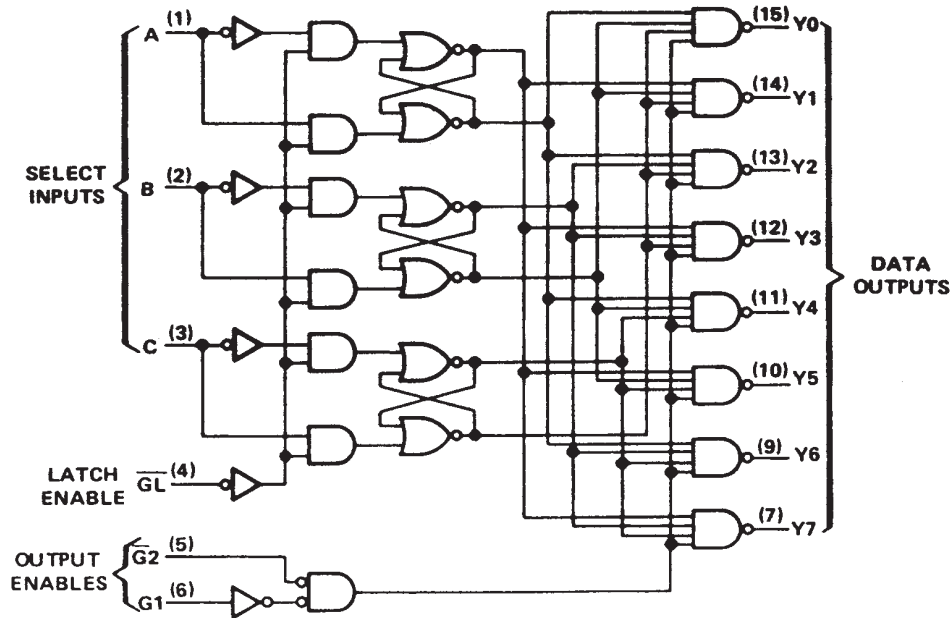

Pin numbers shown are for D, J, N, and W packages.

absolute maximum ratings over operating free-air temperature range (unless otherwise noted)

Supply voltage, V_{CC} (See Note 1)	7 V
Input voltage	7 V
Operating free-air temperature range: SN54LS137	-55°C to 125°C
SN74LS137	0°C to 70°C
Storage temperature range	-65°C to 150°C

NOTE 1: Voltage values are with respect to network ground terminal.



SN54LS137, SN74LS137

3-LINE TO 8-LINE DECODERS/DEMULTIPLEXERS

WITH ADDRESS LATCHES

SDLS132 – JUNE 1978 – REVISED MARCH 1988

recommended operating conditions

	SN54LS137			SN74LS137			UNIT
	MIN	NOM	MAX	MIN	NOM	MAX	
Supply voltage, V_{CC}	4.5	5	5.5	4.75	5	5.25	V
High-level output current, I_{OH}			-400			-400	μ A
Low-level output current, I_{OL}			4			8	mA
Width of enabling pulse at $\overline{G_L}$, t_w	15			15			ns
Setup time at A, B, and C inputs, t_{su}	10			10			ns
Hold time at A, B, and C inputs, t_h	10			10			ns
Operating free-air temperature, T_A	-55		125	0		70	$^{\circ}$ C

electrical characteristics over recommended operating free-air temperature range (unless otherwise noted)

PARAMETER	TEST CONDITIONS [†]	SN54LS137			SN74LS137			UNIT	
		MIN	TYP [‡]	MAX	MIN	TYP [‡]	MAX		
V_{IH} High-level input voltage		2			2			V	
V_{IL} Low-level input voltage				0.7			0.8	V	
V_{IK} Input clamp voltage	$V_{CC} = \text{MIN}$, $I_I = -18 \text{ mA}$			-1.5			-1.5	V	
V_{OH} High-level output voltage	$V_{CC} = \text{MIN}$, $V_{IH} = 2 \text{ V}$, $V_{IL} = V_{IL \text{ max}}$, $I_{OH} = -400 \mu\text{A}$	2.5	3.5		2.7	3.5		V	
V_{OL} Low-level output voltage	$V_{CC} = \text{MIN}$, $V_{IH} = 2 \text{ V}$, $V_{IL} = V_{IL \text{ max}}$			0.25	0.4		0.25	0.4	V
							0.35	0.5	
I_I Input current at maximum input voltage	$V_{CC} = \text{MAX}$, $V_I = 7 \text{ V}$			0.1			0.1	mA	
I_{IH} High-level input current	$V_{CC} = \text{MAX}$, $V_I = 2.7 \text{ V}$			20			20	μ A	
I_{IL} Low-level input current	$V_{CC} = \text{MAX}$, $V_I = 0.4 \text{ V}$							mA	
I_{OS} Short-circuit output current [§]	$V_{CC} = \text{MAX}$	-20		-100	-20		-100	mA	
I_{CC} Supply current	$V_{CC} = \text{MAX}$, See Note 2		11	18		11	18	mA	

[†] For conditions shown as MIN or MAX, use the appropriate value specified under recommended operating conditions.

[‡] All typical values are at $V_{CC} = 5 \text{ V}$, $T_A = 25^{\circ}\text{C}$.

[§] Not more than one output should be shorted at a time, and duration of the short-circuit should not exceed one second.

NOTE 2: I_{CC} is tested with all inputs grounded and all outputs open.

switching characteristics, $V_{CC} = 5 \text{ V}$, $T_A = 25^{\circ}\text{C}$, see note 3

PARAMETER [¶]	FROM (INPUT)	TO (OUTPUT)	LEVELS OF DELAY	TEST CONDITIONS	MIN	TYP	MAX	UNIT
t_{PLH}	A, B, C	Y	2	$C_L = 15 \text{ pF}$, $R_L = 2 \text{ k}\Omega$, See Note 3		11	17	ns
t_{PHL}			4			25	38	
t_{PLH}	A, B, C	Y	3			16	24	ns
t_{PHL}			3			19	29	
t_{PLH}	Enable $\overline{G_2}$	Y	2			13	21	ns
t_{PHL}			2			16	27	
t_{PLH}	Enable G1	Y	3			14	21	ns
t_{PHL}			3			18	27	
t_{PLH}	Enable $\overline{G_L}$	Y	3			18	27	ns
t_{PHL}			4			25	38	

[¶] t_{PLH} = propagation delay time, low-to-high-level output.

t_{PHL} = propagation delay time, high-to-low-level output.

NOTE 3: Load circuits and voltage waveforms are shown in Section 1.

